

#1 YARD RAMP IN AMERICA

MOBILE CONTAINER RAMP & DOCK TO GROUND RAMP

Installation and Owner's Manual

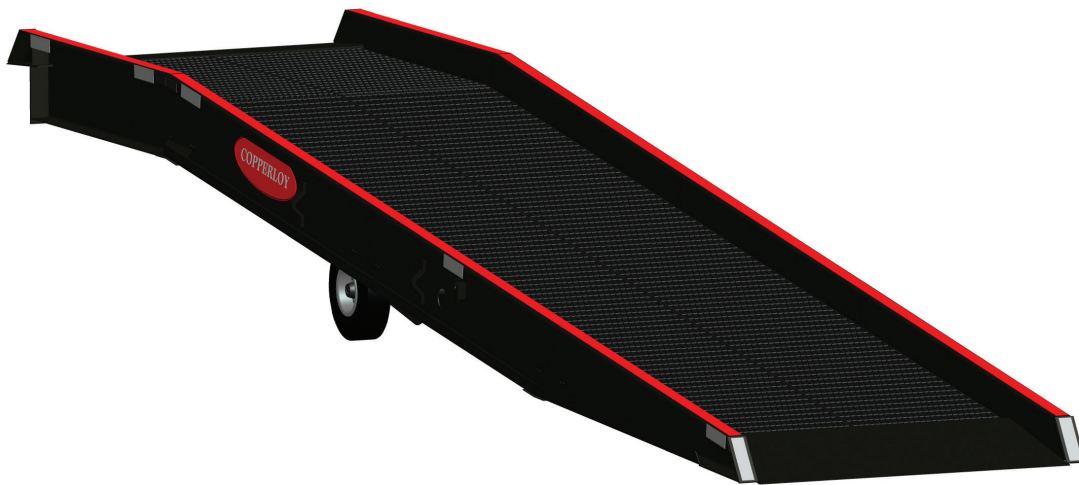

WARNING:

Do not install, operate or service this product unless you have read and understand the Safety Practices, Warnings, Installation and Operating Instructions contained in this manual before . Failure to do so could result in serious injury or death.



by JH INDUSTRIES, INC.

Model # _____

Serial # _____

Date: _____



This page left blank intentionally



WARRANTY

ALL WARRANTY CLAIMS MUST HAVE PRE-APPROVED RATES, TIMES AND AUTHORIZATION NUMBERS PRIOR TO ANY FIELD WORK, IN ORDER TO BE ACCEPTED BY JH INDUSTRIES, INC.

J H Industries, Inc. expressly warrants that any MOBILE YARD RAMP sold by it will be free from defects in material and workmanship under normal use for a period of five (5) years on all structural parts and one (1) year on all steel grating and hydraulic parts from the earlier of, 1) sixty (60) days after the date of shipment, or 2) the date of installation of the MOBILE YARD RAMP by the original purchaser, provided the purchaser maintains and operates the MOBILE YARD RAMP in accordance with the Owners Manual.

In the event that the MOBILE YARD RAMP proves to be defective in materials or manufacturing workmanship within the applicable period, J H Industries, Inc. will, at its option:

1. Replace the MOBILE YARD RAMP or the defective portion thereof without charge to the purchaser, or
2. Alter or repair the MOBILE YARD RAMP, on site or elsewhere, without charge to the purchaser.

This warranty IS EXCLUSIVE AND IS IN LIEU OF ALL GUARANTEES AND WARRANTIES, EXPRESSED OR IMPLIED BY ANYONE OTHER THAN J H Industries, Inc. sole warranty obligation shall be as set forth above. JH Industries, Inc. reserves the right at any time and only with prior written notification to change or alter the warranties expressed and provided.

The warranty does not cover any failure caused by improper installation, abuse, misapplication, overloading, negligence, or failure to maintain the MOBILE YARD RAMP properly. Parts requiring replacement due to damage resulting from vehicle impact, abuse, improper operation or lack of proper protection are not covered by this warranty. Seller assumes no responsibility or liability for (1) consequential damages of any kind which result from the use or misuse of the MOBILE YARD RAMP; (2) damage or failure resulting from the use of unauthorized replacement parts or modification to the MOBILE YARD RAMP; (3) damage resulting from the misuse of the MOBILE YARD RAMP. THERE ARE NO WARRANTIES, EXPRESSED OR IMPLIED, WHICH EXTEND BEYOND THE DESCRIPTION ABOVE. THERE IS NO WARRANTY OF MERCHANTABILITY OR OF FITNESS FOR A PARTICULAR PURPOSE.

J H Industries, Inc. warranties extend only to the product itself.

J H Industries, Inc. DISCLAIMS all liability arising out of the workmanship, methods and materials used by the installer.

J H Industries, Inc. DISCLAIMS all liability for premature wear, product failure, property damage or bodily injury arising from improper installation or maintenance.

WARRANTIES, whether expressed or implied, relating to workmanship and materials used in connection with the installation of J H Industries, Inc. products are specifically DISCLAIMED.

INTRODUCTION

Welcome, and thank you for purchasing your Mobile Yard Ramp from Copperloy by JH Industries Inc. It is designed to give you many years of trouble-free operation.

This manual contains information that is needed to operate and maintain the ramp safely. It also contains a complete parts list and information about ordering replacement parts. Please read completely before using your new Mobile Yard Ramp.

This manual also contains a complete parts list and information about ordering replacement parts. JH Industries, Inc. has selected components for best fit and function for each of our products, therefore replacement parts should be identical to original equipment or have written approval for non-original equipment. ***JH Industries, Inc. will not be responsible for equipment failures due to incorrect or non-approved replacement parts.***

Verify that this is the most current Installation, Operation and Service Manuals.

To obtain an updated version please contact:

JH Industries Inc.

1981 E. Aurora Rd.

Twinsburg, Ohio 44087

(330) 963-4105 (Phone) or 1-800-321-4968 (toll free)

Or visit our website under Mobile Container Ramps to download and print an up to date manual.

www.copperloy.com



TABLE OF CONTENTS

WARRANTY.....	1	RUNNING GEAR.....	10-11
INTRODUCTION.....	1	TROUBLE SHOOTING.....	12-13
TABLE OF CONTENTS.....	2	UNDERCARRIAGE.....	14
SAFETY.....	2	MOBILE RAMP PARTS LIST.....	15-16
SAFETY PRACTICES.....	3	WHEEL ASSEMBLY.....	16
RECOMMENDED UNLOADING PROCEDURES.....	4-5	GRATING PARTS LIST.....	17
INSTALLATION DOCK TO GROUND.....	6	PUMP ASSEMBLY.....	18
OPERATING INSTRUCTIONS.....	7-9	PUMP PARTS LIST.....	19
MAINTENANCE.....	9	CLYINDER PARTS LIST.....	20
HYDRAULIC SYSTEM.....	10	MOBILE RAMP SAFETY LABELS.....	21
		DOCK TO GROUND SAFETY LABELS.....	22
		NOTS.....	23

SAFETY

A product safety sign or label should alert persons to a specific hazard, the degree or level of hazard seriousness, the probable consequence of involvement with the hazard, and how the hazard can be avoided. **SIGNAL WORD** is a word or words that designate a degree or level of hazard seriousness. The signal words for product safety signs are **“DANGER, WARNING, CAUTION”** and **“NOTICE”**. Below is each of these signal words along with their definitions as directly referenced from *ANSI Z535.4-1998*.

DANGER

Indicates an imminently hazardous situation which, if not avoided, will result in death or serious injury. This signal word is to be limited to the most extreme situations.

WARNING

Indicates a potentially hazardous situation which, if not avoided, could result in death or serious injury.

CAUTION

Indicates a potentially hazardous situation which, if not avoided, may result in minor or moderate injury. It may also be used to alert against unsafe practices.

NOTICE!

“NOTICE” is the preferred signal word to address practices not related to personal injury. The safety alert symbol shall not be used with this signal word. As an alternative to “NOTICE”, the word “CAUTION” without the safety alert symbol may be used to indicate a message not related to personal injury.

SAFETY PRACTICES

⚠ WARNING

Read and follow all safety practices, manuals, and instructions before installing, operating or servicing the ramp. Failure to follow these safety practices and instructions could result in property or equipment damage and serious injury or death.

READ AND FOLLOW THE OPERATING INSTRUCTIONS CONTAINED IN THIS MANUAL BEFORE OPERATING THE LIFT. If you do not understand the instructions or safety practices ask your supervisor or consult the factory for assistance.

This equipment should be used and maintained only by qualified personnel.

Failure to do any of the above could result in serious injury or death.

FOR ALL MODELS

ONLY trained personnel are to operate or service ramp. Follow all procedures and warnings in the service manual or posted on the ramp.

NEVER exceed 5 mph when driving on ramp.

NEVER exceed the rated capacity of ramp.

NEVER travel on ramp unless lip is securely on dock or carrier floor and properly attach safety chains in accordance with this manual. Visually check that the lip is supported and has a minimum of 4" of overlap onto the dock or carrier floor.

DO NOT use the ramp with equipment, material or people on or in front of the ramp or lip.

DO NOT use the ramp if it looks damaged. Tell your supervisor it needs repair right away.

DO NOT use this unit to dock heights outside its intended working range.

If you have any problems or questions using the ramp, **STOP** and contact your supervisor for assistance.

DO NOT stop truck or attempt to change gears while ascending or descending ramp.

ALWAYS traverse the ramp with the forks towards the dock or elevated end.

DO NOT attempt to lift or lower the ramp lip by any

means other than described in the operation procedures contained in this manual. Keep all body parts clear of the ramp at all times and maintain a safe distance from the underside of the ramp while raising or lowering.

DO NOT operate the ramp if operation causes undue physical strain or if physical impairments could lead to undue strain in back, muscles, limbs or joints.

DO NOT use ramp if either of the chains are missing or if the chains are not securely in place.

NEVER crawl or work under, walk or drive on any ramp that is not resting on and chained to a suitably stable and sturdy support such as a carrier bed or loading dock.

FOR MOBILE CONTAINER RAMPS

DO NOT use ramp if petcock valve is closed.

DO NOT use drive on or place any weight on ramp if release valve on pump is in the closed position.

DO NOT use ramp if carrier wheels are not chocked and support jacks under the trailer are not being used.

Many trailers have air ride suspensions that may cause the trailer to move away from the ramp during loading and unloading operations. The potential for this movement can be reduced by exhausting or "dumping" the air from the air ride suspension system before servicing the trailer. Make sure attached chains are used to secure the ramp to the trailer.

NEVER permit a carrier to pull away and allow the ramp to fall to the ground.

ALWAYS store the ramp in the lowered position.

NEVER use the positioning sleeve for towing.

NEVER skid a ramp sideways, **ALWAYS** position the ramp by rolling on its wheels.

NEVER place your hands or any body part between the ground and tow bar.

Ramp, refers to all models including Mobile Container Ramp, Yard Ramp, Dock to Ground Ramp. Ramp will be used throughout this manual to describe all models.

RECOMMENDED UNLOADING PROCEDURES

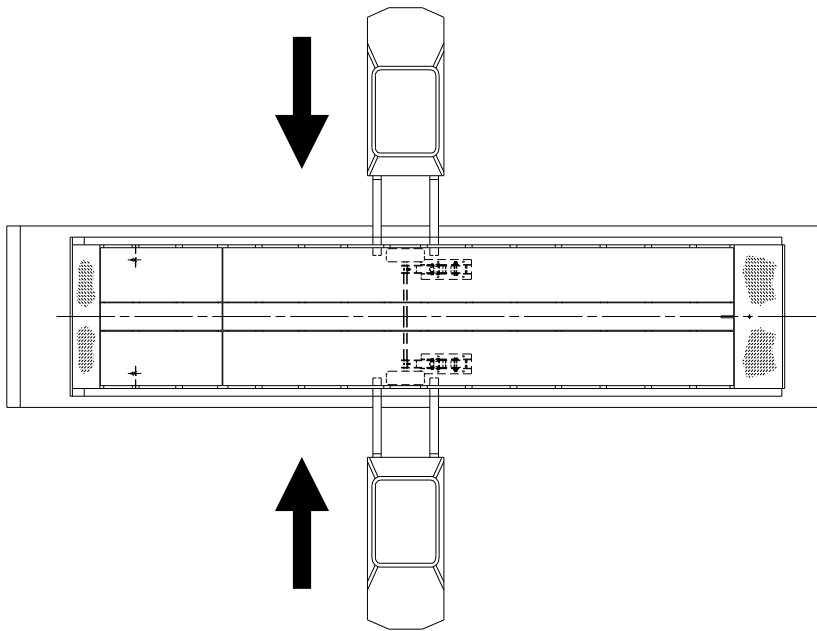

STEP #1:

After carrier comes to a complete stop and sets brakes, remove hold down straps and release ramp chains.

STEP #2:

Position lift trucks on both sides of ramp, spread forks as wide as possible. The lift truck capacity must be sufficient to lift the ramp at a distance near the fork end. See the shippers B/L for the actual weight of the ramp.

STEP #3:

Slowly move lift trucks forward. Not more than 9" of fork tip should engage the ramp side girder.

STEP #4:

Slowly and uniformly lift the ramp until it is clear of the carrier and all supports.

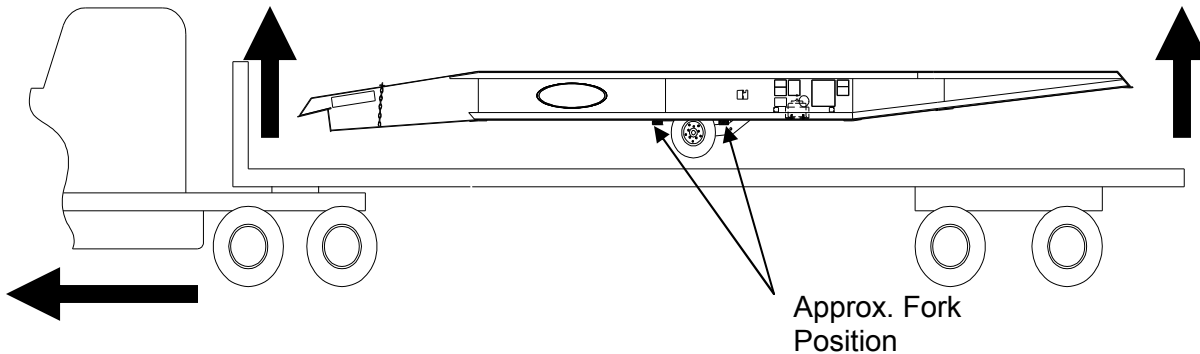

STEP #5:

Have carrier drive pull forward and completely clear of ramp. Then slowly and uniformly lower ramp to the ground.

CAUTION

Failure to open the petcock valve can cause damage to the hydraulic system and create back pressure in the tank which could result in damage to the Ramp or injury to personnel.

STEP #6:

Verify the hydraulic system works, see the OPERATION section in this manual. If there are any issues please contact the factory.



RECOMMENDED UNLOADING PROCEDURES

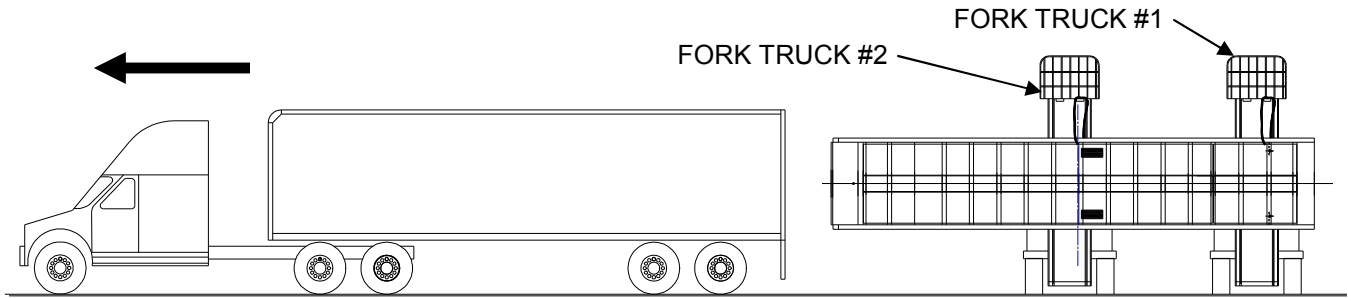

STEP #6:

Once the ramp is clear of the trailer floor slowly drive the truck forward. With the ramp clear position wood under the location of the ramp on the ground. Keep both slings taught at all times.

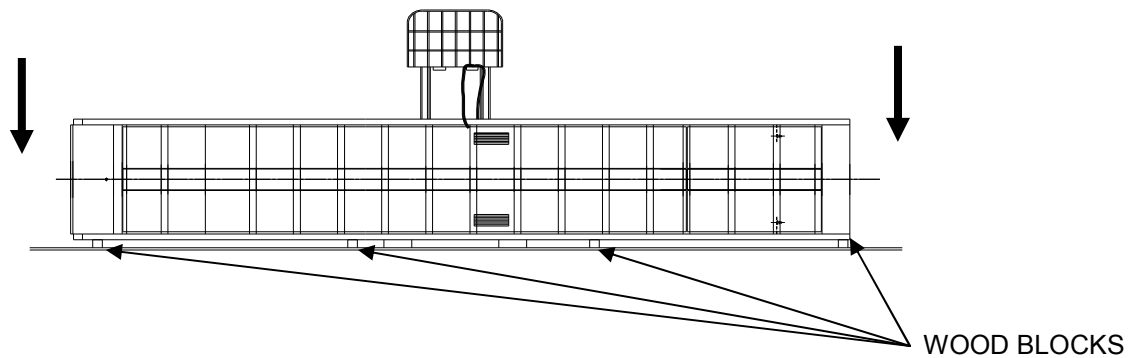

STEP #7:

Set the ramp slowly onto the wood blocks while keeping Fork Truck #2 sling taught remove the sling from Fork Truck #1 and drive fork truck clear of ramp.

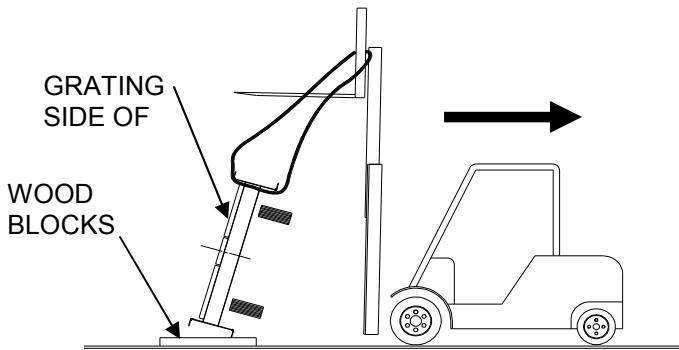

STEP #8:

Keep the ramp resting on the wood blocks and slowly back the fork truck while lowering the forks until the ramp is resting on it's wheels or bottom side. Check the ramp for any damage and **OPEN THE PETCOCK VALVE** located on the hydraulic pump on Mobile Ramps (See Figure #5).

The reservoir is equipped with a petcock valve in the filler plug. The valve is closed for shipping and must be opened for proper operation. Turn counterclockwise until it stops. (See Figure #5)

CAUTION

Failure to open the petcock valve can cause damage to the hydraulic system and create back pressure in the tank which could result in damage to the Ramp or injury to personnel.

STEP #9:

Verify the hydraulic system works, see the OPERATION section in this manual. If there are any issues please contact the factory.

WARNING

Read and follow all safety practices and owners manual warnings before installing, operating or servicing the Ramp. Failure to follow above information could result in death or serious injury.

INSTALLATION DOCK TO GROUND RAMP

⚠ WARNING

Read and follow all safety practices and owners manual warnings before installing, operating or servicing the Ramp.

Use by untrained personnel could result in serious injury or death. **DO NOT USE THE RAMP IF IT LOOKS DAMAGED OR DOES NOT SEEM TO WORK PROPERLY.** Tell your supervisor it needs repair.

Failure to follow the information provided could result in death or serious injury.

If you do not understand the instructions or if you have any problems or questions using or operating the Mobile Container Ramp, contact your supervisor or the factory for assistance.

1. PREPARE SITE:

If required, pour a concrete footer or apron per local codes and conditions. Allow to fully cure before installation of ramp. See Figure 1.

2. INSTALL SAFETY CHAIN BRACKETS:

See Figure 3 for locating both safety chain brackets provided with Dock to Ground Ramp. Use the bracket to locate the mounting hole locations. Using 5/8" dia. anchor bolts secure safety chain brackets to the dock wall.

⚠ WARNING

All anchor bolt lengths must suit local codes and conditions. Type and depth of concrete will determine type and length of anchor bolts required. Improperly sized anchor bolts could allow the safety chain brackets to fail resulting in serious injury or death.

3. PLACING RAMP:

Square up and locate ramp in position on the dock surface, keeping the bumper plates as close to the dock face as possible, to prevent ramp movement. See Figure #2.

4. ATTACH SAFETY CHAINS:

Attach both safety chains to safety chain brackets on dock wall. Allow as little amount of slack in

chains as possible to prevent ramp from moving away from dock face. See Figure #2.

⚠ WARNING

Safety chains that are not attached properly may cause the ramp to move and fall free from the dock surface, resulting in equipment damage, serious injury or death.

FIGURE #1

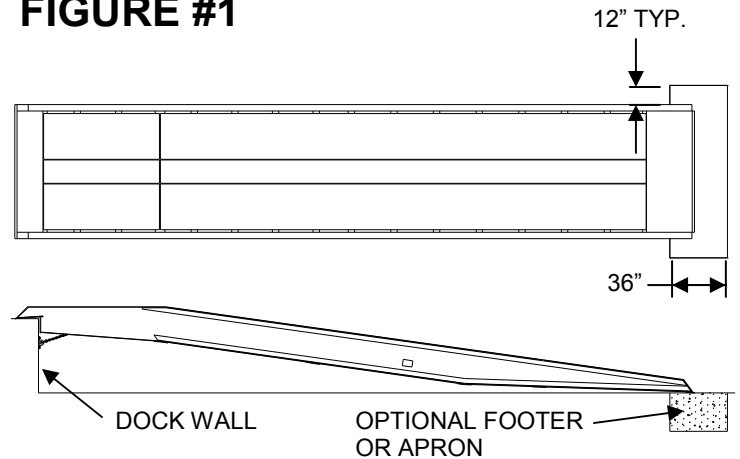

FIGURE #2

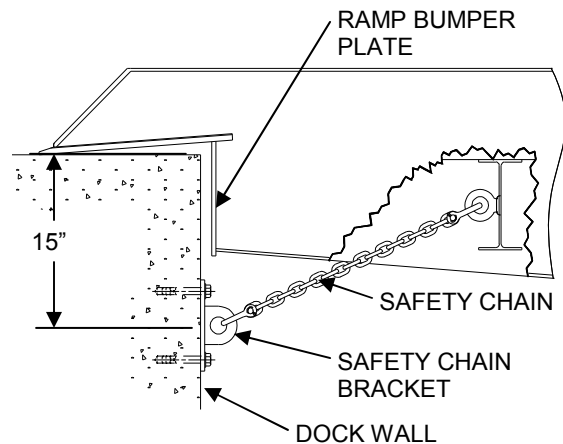
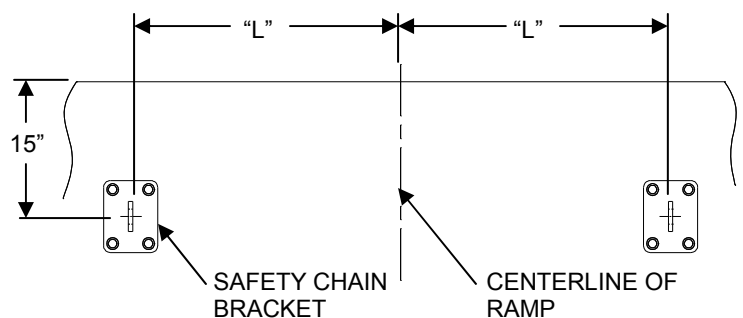

FIGURE #3



OPERATION MOBILE RAMP

SAFETY CHAIN BRACKET LOCATION CHART			
Ramp Width	70"	84"	96"
"L"	30"	37"	43"

1. ELEVATE:

To elevate the ramp, close the pump release valve by turning the lever clockwise. (See Figure #2) The valve seat is a precision type and does not require force beyond finger tight. Overturning may damage the valve seat. The pump is located under the grating on the left hand side of the ramp and is accessible by reaching through the opening in the side of the ramp.

Take the pump handle from its storage bracket on the outside of the ramp along the lower flange of the side girder. On the aluminum ramp the handle is stored along the cross beam. Accessible through the opening in the side of the ramp at the pump. Place it through the grating onto the pump handle adapter. Oscillate the pump until the ramp is slightly higher than the carrier. It may take a few strokes before the full pressure is felt in the handle.

Return the handle to its storage bracket when not in use.

CAUTION

DO NOT LEAVE THE HANDLE IN THE PUMPING POSITION. Damage or injury can occur if the pump handle is left in the hydraulic pump.

2. POSITION:

Move the ramp ahead until the lip apron is completely over the carrier floor, and the stop plates are against the carrier door sill. Always position the ramp to the trailer. Do not back up trailers against the ramp.

Slowly open the pump release valve by turning counter clockwise. The ramp will settle onto the carrier floor.

WARNING

The release valve must be left in the open position when the Mobile Container Ramp is in use. Failure to do so could result in death, serious injury or property damage.

This allows the understructure and hydraulics to float freely so that no load is transferred on the running gear. The ramp is designed as a single span bridge, supported at the ends only, with no load on the wheels.

Refer to the POSITIONING SLEEVE, section #8 for additional information on positioning.

3. SECURE:

Loop the two safety chains supplied on the ramp around the carrier frame and lock with grab hooks. Allow as little amount of slack in chains as possible to prevent ramp from moving away from the carrier.

WARNING

Do not use the ramp if either of the chains are missing, damaged or if the chains are not securely in place. Chock carrier wheels and use support jacks under the trailer as required. (OSHA Requirements) Accidental separation of ramp and carrier may result in serious injury or death.

If the ramp is to be used at a loading dock or other fixed platform, make sure the platform is equipped with hook or eye devices firmly anchored in place to receive the Container Ramp safety chains as outlined.

4. OPERATION (Mobile & Dock to Ground Ramps):

Verify the PUMP RELEASE VALVE is in the OPEN POSITION. (See Figure #2)

Approach the ramp in low gear and maintain an even rate of climbing speed.

Always traverse the ramp with the forks towards the carrier or elevated end. Fork trucks should **ASCEND AND DESCEND** the ramp in **LOWEST GEAR**.

All lift truck safety and operation standards of ASME/ANSI B56.1-1993 (incl. latest addenda) should be followed.

WARNING

Do not stop, start or change speeds of truck on ramp. Failure to do so could result in death or serious injury.



OPERATION MOBILE RAMP, CONTINUED

5. LOADING/UNLOADING COMPLETED:

Be sure that the lift truck is off and clear from the ramp. Unhook both safety chains and disengage ramp from carrier.



Do not walk or drive on the ramp when the ramp is not resting on a firm support at the lip end. Failure to do so could result in death or serious injury.

Unhook both safety chains from the truck frame.

Close the pump release valve (turn lever clockwise) finger tight only.

Slide the pump handle on to the pump handle adapter, and oscillate the pump to raise the ramp a few inches above the carrier floor.

The carrier may now pull away, or move the ramp (by means of the **Positioning Sleeve**) to the next location. **Be sure all personnel and objects are cleared from under and around the ramp before moving.**

Refer to the **Positioning Sleeve or Towbar** sections of this manual for correct use of these accessories.



Never permit a carrier to pull away and allow the ramp to fall to the ground. Failure to do so will cause severe damage to the ramp and death or serious injury to personnel.

6. LOWERING THE RAMP:

Be sure that all objects and personnel are cleared from under the ramp. Slowly open the release valve to lower the ramp. Turn the release valve lever counter-clockwise. **Leave the valve in the open position.**



Always store the ramp in the lowered position. Failure to do so could result in serious injury or death.

Do not attempt to manually lift the ramp, death or serious injury could result.

Do not place hands, head, feet or any part of person between the ground and the ramp or towbar. Failure to do so could result in death or serious injury.

7. TOWING: (TOWBAR)

If the ramp has been ordered with an optional towbar accessory, attach it to the ramp as follows:

Open the pump release valve, and let the ramp settle into the lowered position. Place the towbar hook in position between the grating panels on the lateral centerline of the ramp.

Raise the low end of the ramp until the towbar clears the ground and block it in position. Use a lift truck for all lifting.

Swing plate 'A' under the ramp approach plate.

Turn handle 'B' clockwise until tight.

When towbar is secure, ramp is ready for towing.

Recommended Towing Speeds

Without spring assemblies.....5 MPH Max.

8. POSITIONING SLEEVE:

If the ramp is equipped with a positioning sleeve, standard on steel frame ramps, optional on aluminum frame ramps, install it as follows:

Insert the positioning sleeve lug into the hole in the approach plate of the ramp, and swing the sleeve down flat against the plate. Insert one fork into the sleeve the full 18" depth.

Attach the chain from the sleeve through the lift truck fork carriage and secure the grab hook to the chain. Remove as much slack from the chain as possible.

With the positioning sleeve secured, raise the forks so the ramp is 4"-6" clear of the ground. Travel speed for positioning is not to exceed 2 MPH.

Return the sleeve to the storage bracket when not in use.



OPERATION MOBILE RAMP & MAINTENANCE

⚠ WARNING

This Positioning Sleeve is not for towing, it is for positioning and traveling over short distances. Failure to do so could result in death or serious injury.

Positioning distances may be up to several hundred yards with this device. Beyond that distance use the TOWBAR as outlined in this manual.

⚠ WARNING

Extreme caution must be exercised when using transport devices. Attention must be given to all persons and property in the path of travel. Failure to do so could result in equipment damage, property damage, and death or serious injury.

complete hydraulic system and running gear assemblies are located below the main deck surface.

⚠ WARNING

The ramp must be supported and held securely before maintenance personnel are permitted to go under the ramp. Failure to do so could result in death or serious injury.

The support should be placed under the lip apron end and must be suitably stable and sturdy. Acceptable supports are load bearing structures such as loading docks. Do not use lumber or steel members as a vertical post brace. The safety, locking chains supplied with the ramp must also be used to secure the ramp to the supports. **DO NOT DRIVE ON THE RAMP WHEN IN THE BLOCKED POSITION.**

MAINTENANCE

1. BLOCKING INSTRUCTIONS:

Most maintenance work on a Ramp will be performed from the underside of the ramp. The

Be sure no foreign objects contaminate the hydraulic system. Damage to hydraulic system could occur.

MAINTENANCE SCHEDULE

	Schedule	Location	Description of Maintenance Performed
Structure	Based on Usage (Min. Yearly)	Entire Ramp	Inspect for damage or failure of materials or welds
Running Gear (If Applicable)	Base on Usage (Min. Yearly)	Pneumatic Tires	Maintain an air pressure of 100 psi. max.
		Solid Pneumatic Tires	Virtually Maintenance Free
Hydraulics (If Applicable)	Base on Usage (Min. Yearly)	Pump	Damage or excessive wear & leakage
			Check level and life of hydraulic oil
		Perform a ramp descent rate test. Measure at the lip end of the ramp the average distance per second the ramp falls when the pump release valve is opened. (Should be 6" per second if flow controls are set properly)	
		Hoses	Inspect for damage or leaks
		Cylinders	Damage or excessive wear & leakage
Paint	Yearly	Entire Ramp	Inspect enamel finish, touch up any areas indicating rust with a rust inhibitive coating.
Grating	Yearly	All Grating	Inspect for excessive wear and damage and replace as required.

HYDRAULIC SYSTEM & RUNNING GEAR

1. HYDRAULIC HAND PUMP/RESERVOIR:

The hydraulic system is factory filled and the vent/petcock valve is closed for shipping. However, if at some time fluid needs to be added, follow this procedure: With the ramp in the fully lowered position, remove the filler plug from the top of the pump reservoir. Be sure to clean away any foreign matter so as not to contaminate the fluid in the reservoir. Contaminated fluid is the leading cause of hydraulic system malfunction.

NOTICE!

Use only genuine Enerpac hydraulic oil. The use of any other fluid will render your warranty null and void.



During line bleeding do not allow the ramp to raise, the ramp could fall suddenly causing death or serious injury.

2. LINE BLEEDING:

After filling the reservoir or performing other maintenance of the hydraulic system, it may be necessary to bleed the system of entrapped air. The pump must be at its fully lowered position. Loosen the hose fitting at the cylinder farthest from the pump and, with the release valve closed, slowly operate the pump until the oil flows clear without a sign of air bubbles. Tighten the hose fitting. Repeat the process at the cylinder nearest to the pump. Add oil to the reservoir as required.

3. REMOVING HYDRAULIC CYLINDER:

Elevate the lip end of the ramp and follow "**BLOCKING INSTRUCTIONS**" (pg. 9). If the ramp is in the raised position, slowly open the release valve and let the ramp settle on to the support. If the ramp is to be raised by external means; the pump release valve must be open before the ramp is elevated. **AFTER FOLLOWING THE BLOCKING INSTRUCTIONS**, disconnect the hose from the cylinder to be removed.

Remove the upper and lower cylinder retaining pins and spacers.

To install the new or re-packed cylinder, pull out the

rod. (If rod does not move freely, make sure hydraulic port is clear and open). Place cylinder in position, making sure that the port is at the top. Replace cylinder retaining pins and spacers. Replace hydraulic line, but do not tighten fitting. With release valve still in the open position, use a fork truck to raise the lip end of the ramp clear of the support. Remove the support and slowly lower the ramp into its lowest position. Bleed the hydraulic system as described previously, tighten hose fittings, and add oil as required. (Refer to bleeding instructions above)

4. REMOVING HYDRAULIC PUMP:

The ramp must be in the fully lowered position before starting removal. Disconnect hose from the pump. (See Figure #5)

Remove four (4) hex nuts at the base of the pump reservoir. Take pump off of the bracket. To replace the pump, reverse the procedure. After the pump is installed and attached to the system, bleed the hydraulic lines, add oil as required.

RUNNING GEAR

When preparing to work on any part of the wheel or axel assembly, start with the ramp in the lowest position. The pump release valve must be open. Lift the ramp at the lip end with a fork truck or other suitable means until wheels are slightly off the ground. **FOLLOW BLOCKING INSTRUCTIONS.**

5. REMOVING WHEELS:

Pneumatic tire:

Assemblies are automotive type. Refer to page 16, remove five (5) hex lug nuts and lock washers (Items 1K & 1N Figure #1), and remove wheel from hub assembly (Item 1A Figure #4).

To reassemble tire, reverse the directions above.

6. REPLACING BEARINGS:

Pneumatic tire:

Remove wheel per instructions above. Remove dust cap from hub assembly (Item 1A Figure #1). Remove cotter pin (Item 1J Figure #1), remove spindle nut (Item 1H Figure #1), remove spindle washer (Item 1M Figure #1), hub assembly can now be removed from the axle. Repair hub assembly or

Figure 4

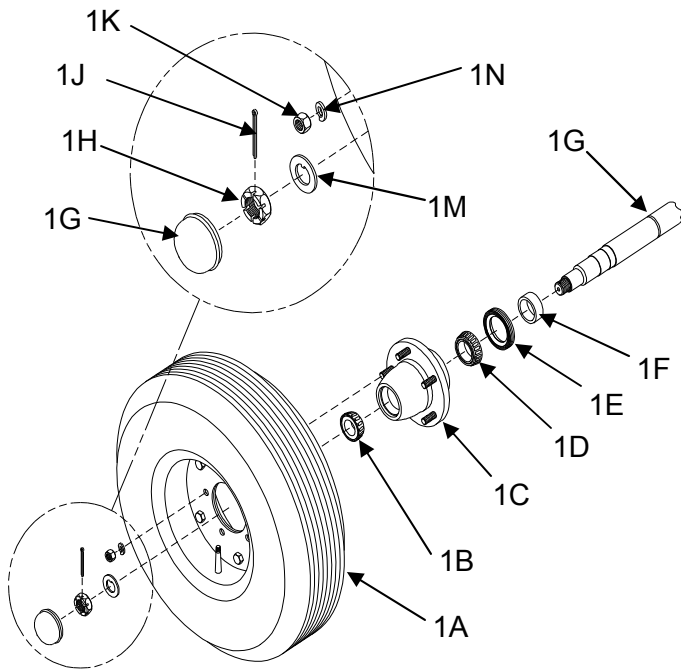

- | | |
|-----------------------------|--------------------------|
| 1A—Wheel Assembly | 1H—Spindle Nut |
| 1B—outer Bearing | 1J—Cotter Pin |
| 1C—Wheel Hub | 1K—Hex Lug Nuts |
| 1D—Inner Bearing | 1M—Spindle Washer |
| 1E—Inner Grease Seal | 1N—Lock Washer |
| 1F—Grease Retainer | 1P—Axle |
| 1G—Dust Cap | |

bearings as necessary. Inner grease seal (Item 1E Figure #1) should be replaced with a new seal when servicing hub assemblies. To reassemble, reverse the procedure above.

7. STEEL CONTAINER/RAMP FRAME:

Annual inspection of the steel frame's enamel finish should be performed. Any areas indicating rust should be thoroughly wire brushed, prime painted, and top coat painted with a good quality rust inhibiting coating. All steel products will begin to show signs of weathering at some point. This general "touch-up" is not to be considered a claim against the products warranty.

⚠ WARNING

No part of your body should be under the ramp while making any of these adjustments, move to safety away from the underside of the ramp.

Figure 5

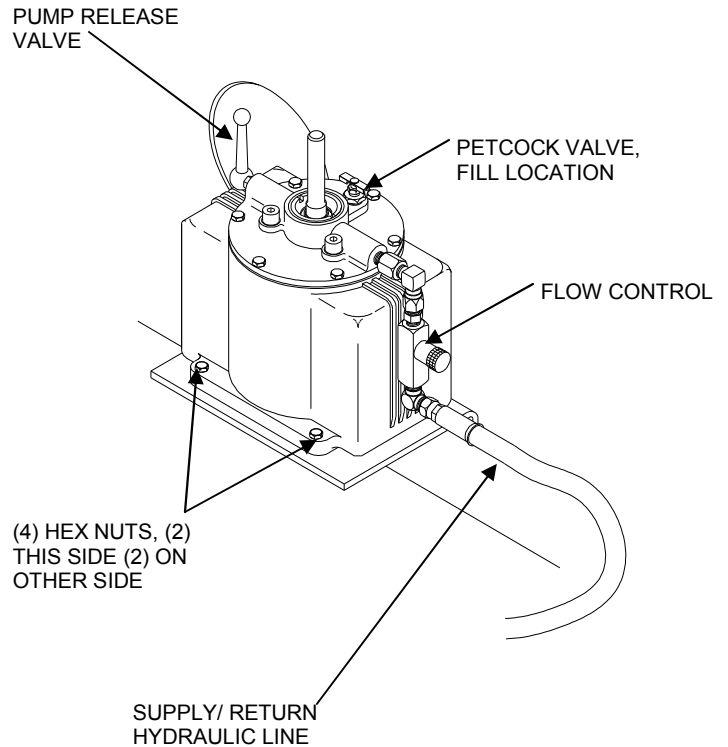

INSIDE VIEW OF SIDE GIRDER

Do not leave the flow control valve in the closed position. This will cut off fluid flow back to the pump. This will be an unsafe condition. Do not use the ramp if it will not lower onto the carrier.

Failure to do so may result in death or serious injury.



TROUBLE SHOOTING

Ramp does not raise	Check hydraulic reservoir oil level.	Fill with hydraulic oil.	See Section 1 of Hydraulic System for filling Instructions
	Check the petcock vent is open for operation.	Open the Petcock Vent.	See Section 1 of Operation to open the Petcock Vent.
	Check for damage to the hydraulic system or physical damage to the running gear.	Replace or repair damaged parts or equipment.	Refer to parts lists and figures for parts listings.
	Check pump release valve for wear or damage.	Replace or repair damaged parts or equipment.	Refer to pump parts list and figure for parts listings.
	Pressure relief valve not adjusted properly. Ramp will attempt to raise but settle back down after pumping.	Readjust pressure relief valve or replace if damaged.	See Section 4 of Hydraulic System for removing hydraulic pump. Refer to pump parts list and figure for parts listings.
	Pump handle should not move on its own. Check to see if the pump handle returns or moves by itself.	Replace the ball check valves.	See Section 4 of Hydraulic System for removing hydraulic pump. Refer to pump parts list and figure for parts listings.
Ramp rises slowly or is hard to pump	At the cylinder: Check for bent or damaged rods.	Replace cylinder	See Section 3 of Hydraulic System for Cylinder Replacement Instructions
	Check for physical damage to the running gear.	Replace or repair damaged parts or equipment.	Refer to parts lists and figures for parts listings.
	At the pump release valve: Check for damage or wear. Pump release valve may not be closing completely.	Replace or repair damaged parts or equipment.	See Section 1 of Hydraulic System to tighten the packing nut.
	Check the petcock vent is open for operation.	Open the Petcock Vent.	See Section 1 of Operation to open the Petcock Vent.
	Check hydraulic oil. Oil could be incorrect viscosity, contaminated or low.	Refill or replace as needed.	See Section 1 of Hydraulic System for filling Instructions
	Check for foreign objects jammed in the running gear or under the ramp.	Remove any foreign objects.	
Ramp does not lower	At the cylinder: Check for bent or damaged rods.	Replace cylinder	See Section 3 of Hydraulic System for Cylinder Replacement Instructions
	Check for physical damage to the running gear.	Replace or repair damaged parts or equipment.	Refer to parts lists and figures for parts listings.
	At the pump release valve: Check for damage or wear.	Replace or repair damaged parts or equipment.	See Section 1 of Hydraulic System to tighten the packing nut.
	Check the petcock vent is open for operation.	Open the Petcock Vent.	See Section 1 of Operation to open the Petcock Vent.
	Check the flow control settings.	Readjust flow controls or replace damaged parts.	Final adjustment should permit the ramp to lower at a rate of 6" per second measured at the lip end of the ramp.
	Check for foreign objects jammed in the running gear or under the ramp.	Remove any foreign objects.	
Oil Leakage	At the cylinder: Check for scored rod, wear or damage to cylinder.	Replace cylinder	See Section 3 of Hydraulic System for Cylinder Replacement Instructions
	At the pump filler plug: Check Oil level, too much oil in the reservoir due to improper filling will cause excess oil to be forced out	Remove Oil from reservoir.	See Section 1 of Hydraulic System for filling Instructions
	At the pump release valve: Check for damage or wear.	Tighten the packing nut. Re-pack the stem using the repair kit.	See Section 1 of Hydraulic System to tighten the packing nut. Refer to pump parts list and figure for parts listings.

TROUBLE SHOOTING

Figure 3

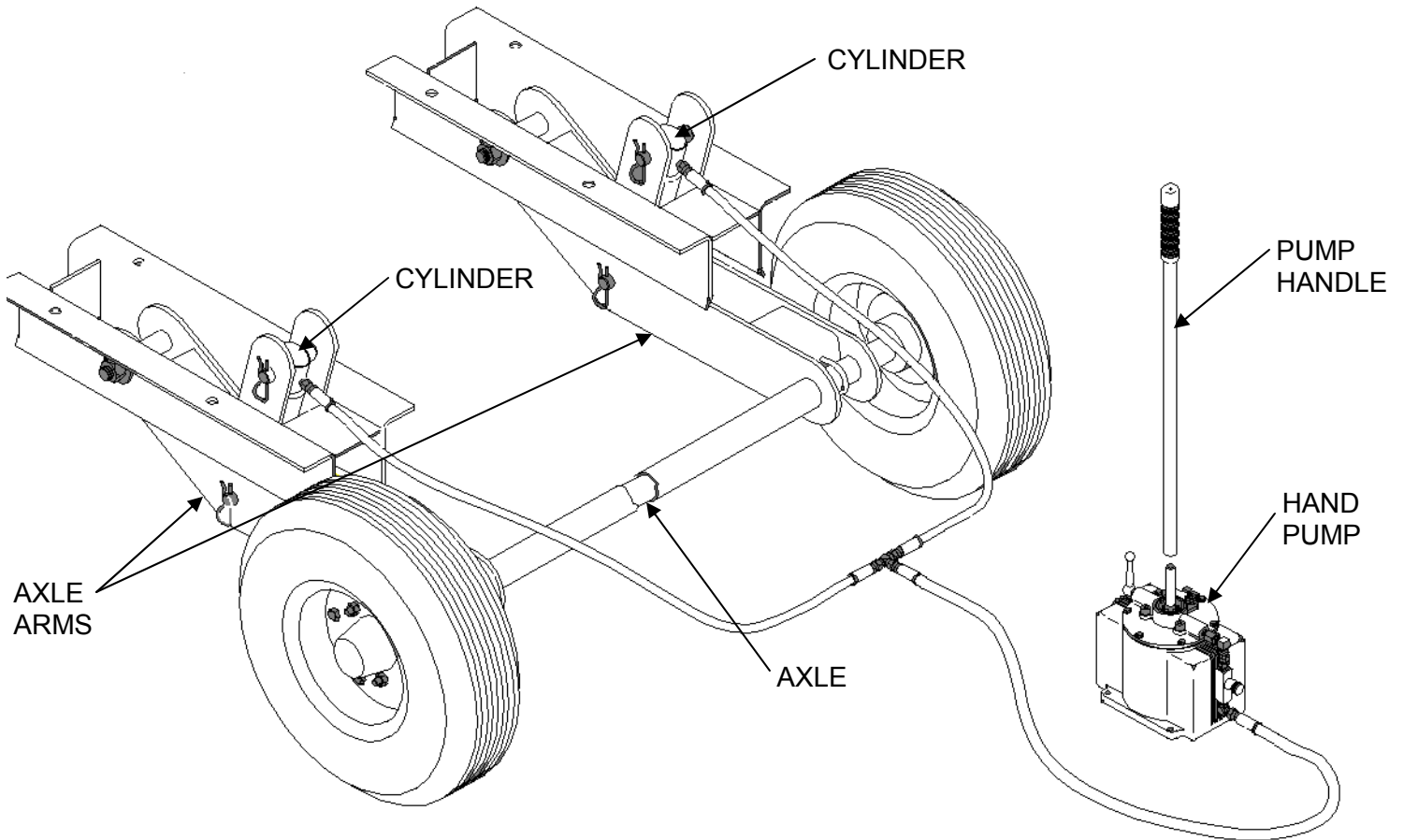

Uneven Raising	Difference in cylinder packing or cylinder tightness.	Depending on the number of cycles performed, a week or so of use will typically remedy the	See Operation in the instruction manual.
	Check for air in the hydraulic system.	Raising or lowering the ramp may self bleed the hydraulic system or line bleed the system.	See Section 2 of Hydraulic System for LINE BLEEDING instructions.
	Older Ramps	Replace the cylinders	See Section 3 of Hydraulic System for Cylinder Replacement Instructions
Pump Operates in one direction only	Check pump to make sure lines do not need to be primed.	Rapidly cycle the pump to prime both pick-up tubes or flush contaminants.	See Section 2 of Hydraulic System for PUMP PRIMING instructions.
	Pump may be damaged or worn.	Replace or repair pump.	See Section 4 of Hydraulic System for removing hydraulic pump. Refer to pump parts list and figure for parts

UNDERCARRIAGE ASSEMBLY

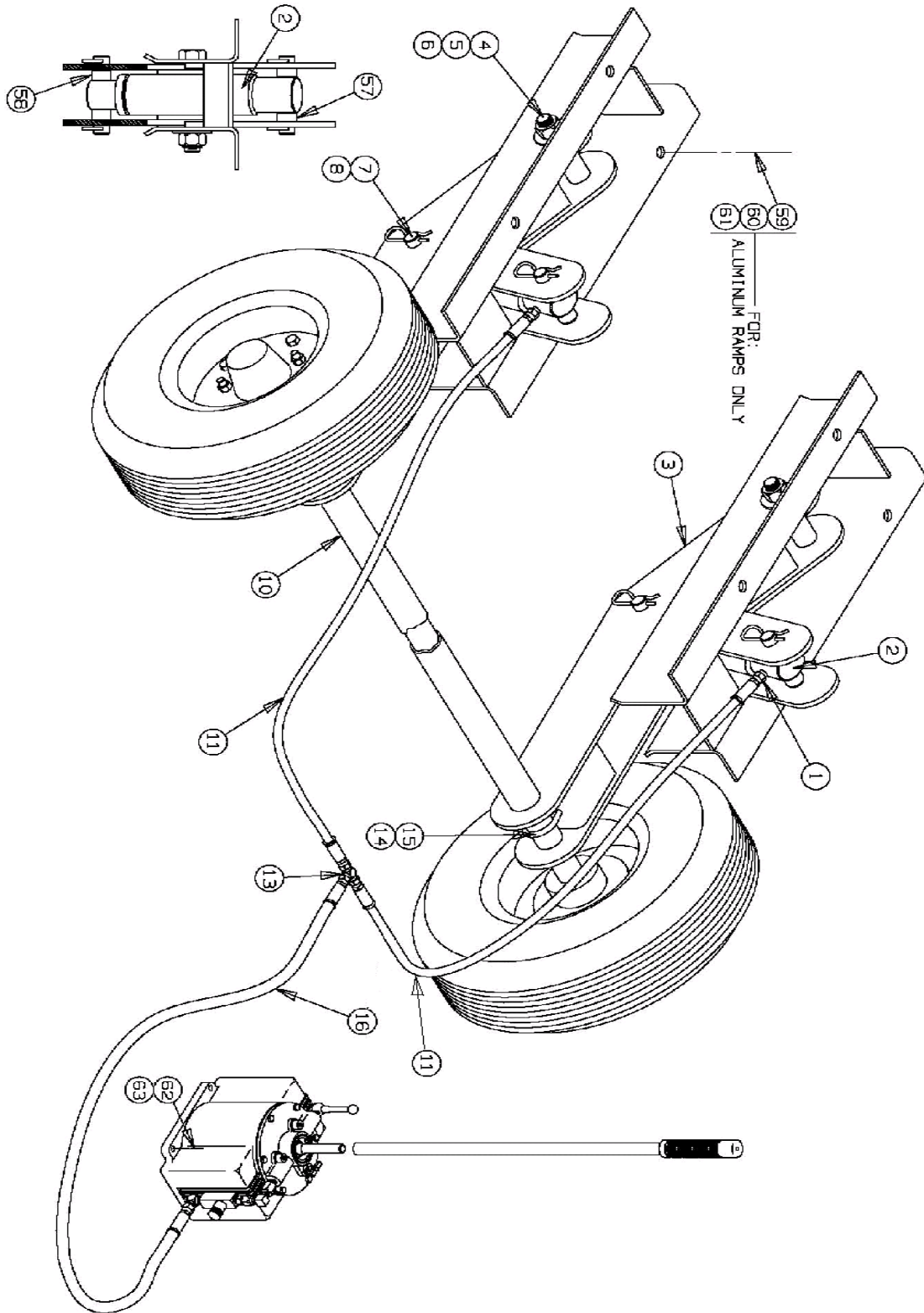



MOBILE RAMP PARTS LIST

ITEM NO.	QTY.	DESCRIPTION	JH PART NO.
1	2	FITTING, HYDRAULIC CYLINDER	024-002
2	2	CYLINDER, HYDRAULIC 2"	045-012
3	2	AXLE ARM	048-025
4	2	HEX LOCKNUT, 1" -8 NC	020-013
5	2	SCREW, HEX HEAD, 1" -8 NC x 6 1/2" LG	002-033
6	2	FLAT WASHER, 1" STANDARD	020-014
7	4	PIN, CYLINDER, 5 1/2" LG	020-022
8	8	PIN, HAIR COTTER, 3/16" DIA.	020-011
9	1	AXLE SLEEVE FOR 70" WIDE RAMP	5367A08
10	1	AXLE SLEEVE FOR 84", 88" & 96" WIDE RAMP	5367A05
11	2	HOSE, HYDRAULIC 72" LG	024-001
13	1	FITTING, TEE CONNECTOR	024-004
14	2	AXLE "U" BOLT	002-030
15	4	AXLE "U" BOLT, NUT	025-004
16	1	HOSE, HYDRAULIC, 24" LG	024-005
23	1	AXLE, 70" WIDE RAMP W/PNEUMATIC TIRES	5282C03
24	1	AXLE, 84", 88" AND 96" WIDE RAMP W/PNEUMATIC TIRES	5282C04
25	2	RETAINER, GREASE, FOR PNEUMATIC TIRES	048-013
26	2	SEAL, INNER BEARING FOR PNEUMATIC TIRES	048-032
27	2	BEARING, INNER FOR PNEUMATIC TIRES	048-032
28	2	HUB, FOR PNEUMATIC TIRES	048-032
29	2	BEARING, OUTER FOR PNEUMATIC TIRES	048-032
30	10	LOCKWASHER, WHEEL LUG	048-032
31	10	HEX NUT, WHEEL LUG	048-032
32	2	PIN, COTTER SPINDLE	048-004
33	2	NUT, SPINDLE	048-003
34	2	WASHER, SPINDLE	048-002
35	2	TIRE & WHEEL ASSEMBLY INCL. TUBE & FLAP 6.50-10	048-035
36	2	SOLID TIRE AND WHEEL ASSEMBLY (OPTIONAL)	048-039
37	2	CAP, DUST, PNEUMATIC TIRE AXLE	048-038
38	2	SHACKLE, ANCHOR ROUND PIN, 7/16" NOM	030-011
39	2	CHAIN, HIGH TEST 5/16" GALV, 96" LG	009-051
40	2	CHAIN, GRAB HOOK CLEVIS TYPE 5/16"	009-001
41	2	CLAMP, HOSE	024-007
42	2	SCREW, SELF THREADING	024-008
43	-	REPAIR KIT, HYDRAULIC CYLINDER (#2 ABOVE)	045-013
51	2	CHAIN, SAFETY (1-8' CHAIN & HARDWARE) ALUMINUM RAMP	2790BA
52	2	CHAIN, SAFETY (1-8' CHAIN & HARDWARE) STEEL RAMP	2790BS
53	-	ASS'Y POSITIONING SLEEVE (ALUMINUM RAMP)	5621CA
54	-	ASS'Y POSITIONING SLEEVE (STEEL RAMP)	5621CS
55	-	TOWBAR COMMERCIAL APPLICATION SMR/SDG	042-042
56	-	TOWBAR COMMERCIAL APPLICATION AS/SS	042-035

CONTINUED ON PAGE 16

MOBILE RAMP PARTS LIST/WHEEL ASSEMBLY

ITEM NO.	QTY.	DESCRIPTION	JH PART NO.
57	4	PIN, SLEEVE (9/16" LG)	048-021
58	4	PIN, SLEEVE (23/32" LG)	020-023
59	8	SCREW, HH GR5 3/4 -10NC X 2 -1/2" LG PLTD	030-006
60	16	WASHER, FLAT SAE 3/4" PLTD	042-028
61	8	NUT, HEX, LOCK REV., GR-B, 3/4 -10NC PLTD	002-099
62	4	WASHER, LOCK 3/8" PLTD	002-057
63	4	NUT, HEX 3/8 -16NC PLTD	024-028
64	2	EYE BOLT 3/4-10NC X 2" LG (FOR ALUMINUM RAMP CHAINS)	037-008
65	2	WASHER LOCK 3/4" PLTD (FOR ALUMINUM RAMP CHAINS)	039-006
66	2	NUT, HEX 3/4-10NC PLTD (FOR ALUMINUM RAMP CHAINS)	039-005

* ITEMS #48, 49 & 50 REQUIRED ON ALUMINUM RAMPS ONLY
 70" WIDE RAMP = 50 PCS. EACH
 84" WIDE RAMP = 60 PCS. EACH

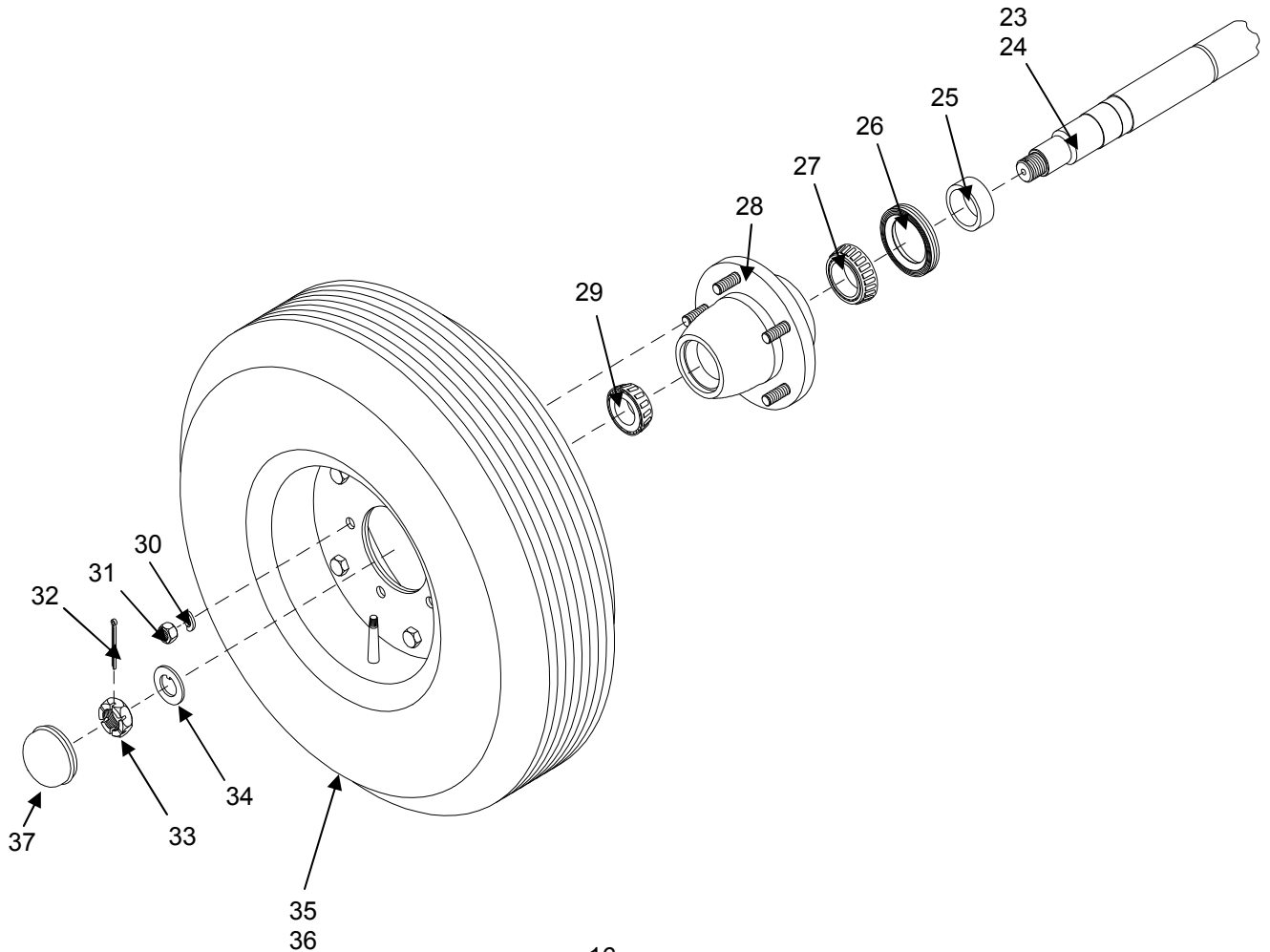

GRATING PARTS LIST

STEEL RAMPS

ITEM NO.	30' STRAIGHT RAMP										36' RAMP WITH 8' LEVEL OFF								DESCRIPTION	PART NUMBER			
	SMRXX-70-30STR	SMRXX-84-30STR	SMRXX-96-30STR	SDGXX-70-30STR	SDGXX-84-30STR	SRXX-96-30STR	SDGXX-102-30-STR	SDGXX-108-30STR	SDGXX-118-30STR	SDGXX-120-30STR	SMRXX-70-36PL8	SMRXX-84-36PL9	SMRXX-96-36PL8	SDGXX-70-36PL9	SDGXX-84-36PL8	SDGXX-96-36PL9	SDGXX-102-36PL8	SDGXX-108-36PL8			SDGXX-118-36PL8	SDGXX-120-36PL8	
1											2											Grating, 1-3/4" Thick, 28-11/16" Wide, 74.25" lg.	CR-02-00648
2												2			2			1	3	3		Grating, 1-3/4" Thick, 35-13/16" Wide, 74.25" lg.	CR-02-00630
3	2		3	2		3	3	2			2		3	2		3	3	2				Grating, 1-3/4" Thick, 28-11/16" Wide, 299-1/4" lg.	CR-02-00647
4		2			2			1	3	3		2		2				1	3	3		Grating, 1-3/4" Thick, 35-13/16" Wide, 299-1/4" lg.	CR-02-00629
5				2	2	2	2	2	2	2				2	2	2	2	2	2	2	2	Pad, Eye, Safety Chain Bracket, Weldment	030-012
6				2	2	2	2	2	2	2				2	2	2	2	2	2	2	2	Chain, Coil, Hi-Test, 5/16"x21"	009-051
7				4	4	4	4	4	4	4				4	4	4	4	4	4	4	4	Shackle, Anchor, Round Pin, 7/16"	030-011

ALUMINUM RAMPS

ITEM NO.	30' STRAIGHT RAMP			36' RAMP WITH 8' LEVEL OFF			DESCRIPTION	PART NUMBER
	A SXX-70-30STR	A SXX-84-30STR	A SXX-96-30STR	A SXX-70-36PL8	A SXX-84-36PL9	A SXX-96-36PL8		
1				2		3	Grating, 2-1/4" Thick, 28-3/4" Wide, 74.25" lg.	025-026
2					2		Grating, 2-1/4" Thick, 14-1/2" Wide, 74.25" lg.	025-028
3	2		3	2		3	Grating, 2-1/4" Thick, 28-3/4" Wide, 299-1/4" lg.	025-025
4		2			2		Grating, 2-1/4" Thick, 14-1/2" Wide, 299-1/4" lg.	025-027
5	40	50	60	50	60	70	Cap Screw, Grating Hold Down (5/16-18NC x 3"LG)	002-078
6	40	50	60	50	60	70	Lock Nut, Grating Hold Down (5/15-18NC)	024-010
7	40	50	60	50	60	70	Clamp, Grating Hold Down	025-007

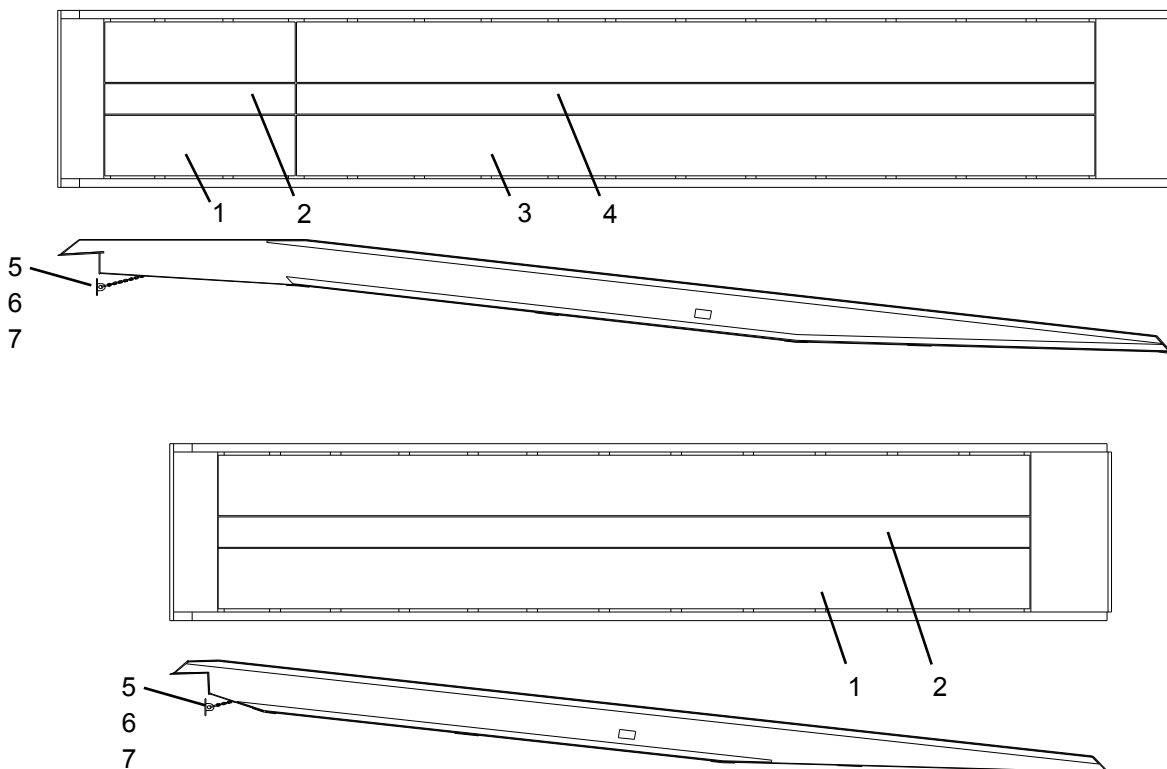

PUMP ASSEMBLY

ASSEMBLY
P/N: 024-069

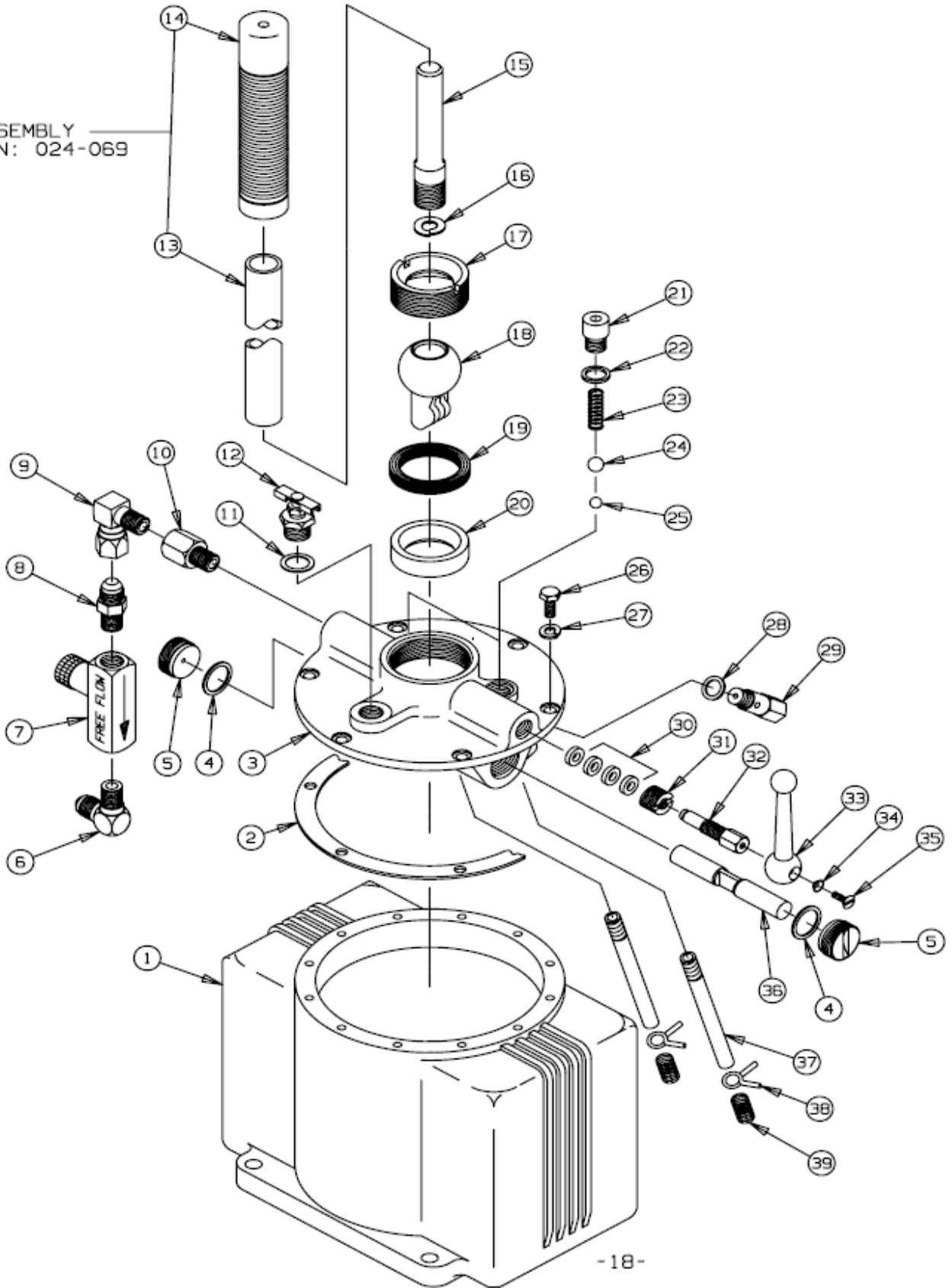



PUMP PARTS LIST

ENERPAC PUMP PARTS LISTING

ITEM NO.	QTY.	DESCRIPTION	JH P/N	REPAIR KIT 024-019	REPAIR KIT 024-029	PUMP ASSY. 024-066	HANDLE ASSY. 024-069
1	1	RESERVOIR				X	
2	1	RESERVOIR GASKET		X		X	
3	1	BASE				X	
4	2	GASKET		X		X	
5	2	PLUG				X	
6	1	90° ELBOW FITTING	024-031				
7	1	FLOW CONTROL	024-037				
8	1	CONNECTOR FITTING	024-062				
9	1	90° ELBOW SWIVEL FITTING	024-067				
10	1	ADAPTER FITTING	024-065				
11	1	GASKET				X	
12	1	VENT PLUG				X	
13	1	PIPE HANDLE	024-070				X
14	1	GRIP	024-024				X
15	1	HANDLE ADAPTER	024-017				
16	1	LOCK WASHER	002-057				
17	1	CAP	024-078			X	
18	1	ROCKER ARM	024-026			X	
19	1	PACKING		X		X	
20	1	SEAT	024-077			X	
21	2	PLUG				X	
22	2	GASKET		X		X	
23	2	SPRING	024-080	X		X	
24	2	BALL		X		X	
25	2	BALL		X		X	
26	6	HEX SCREW				X	
27	6	LOCK WASHER				X	
28	1	GASKET		X		X	
29	1	RELIEF VALVE				X	
30	4	PACKING		X	X	X	
31	1	NUT	024-079		X	X	
32	1	RELEASE VALVE SPINDLE			X	X	
33	1	LEVER			X	X	
34	1	WASHER			X	X	
35	1	SCREW			X	X	
36	1	PISTON				X	
37	2	OIL TUBE				X	
38	2	RETAINING RING				X	
39	2	SCREEN				X	
	NEW	PUMP W/ FLOW CONTROL	024-074				

Use only genuine Enerpac hydraulic oil. The use of any other fluid will render your warranty null and void.

CYLINDER PARTS LIST

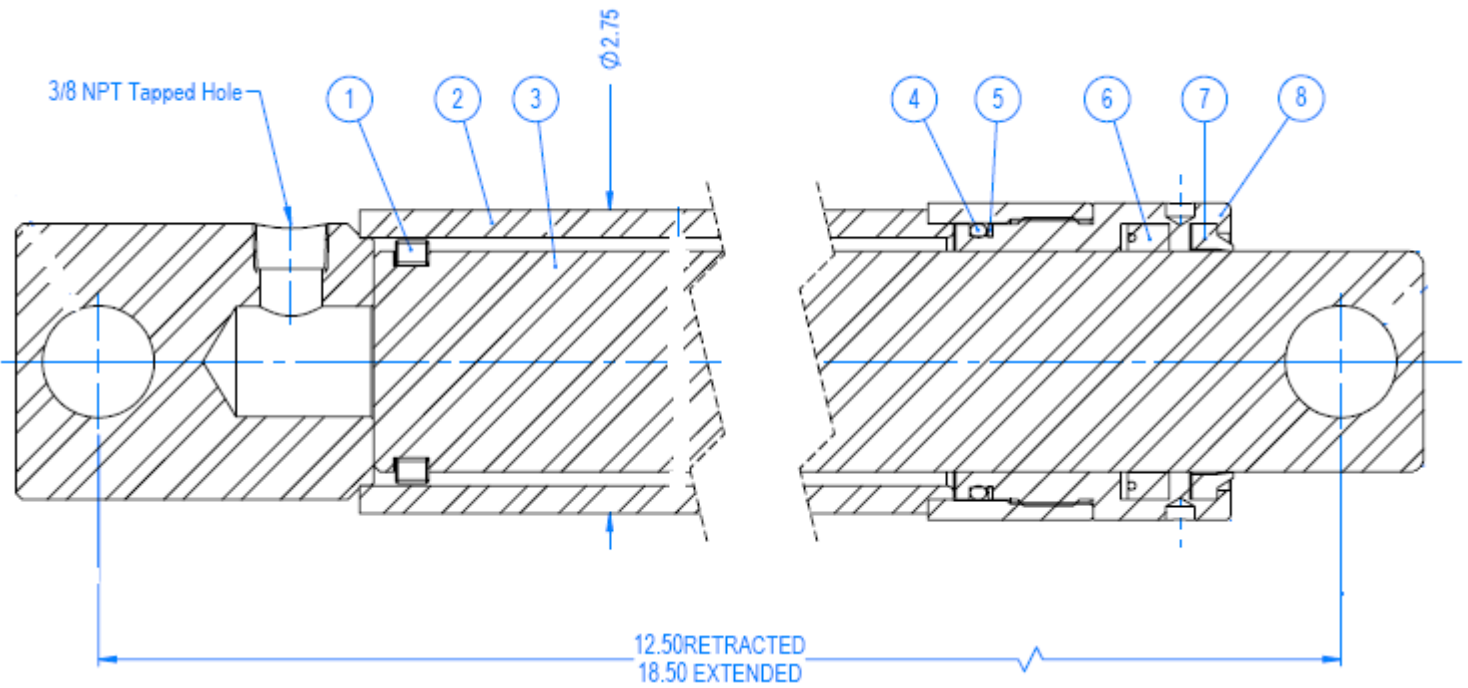

ITEM NO.	QTY.	DESCRIPTION	JH P/N	REPAIR KIT 045-019	Cylinder ASSY. 045-012
1	1	Piston Ring, Split Stop			X
2	1	Jacket Assembly			X
3	1	Rod			X
4	2	Static Seal, O-ring,		X	X
5	2	Back-up Ring, Static Seal		X	X
6	1	Dynamic Seal, Type B		X	X
7	1	Rod Wiper		X	X
8	1	Gland Nut, Internal—No Step			X

MOBILE RAMP SAFETY LABELS

ITEM NO	QTY.	DESCRIPTION	PART NO.
1	2	Capacity Label	12-00102
2	2	Safety Chain Warning Label	12-00101
3	2	Copperloy Logo Label	
4	1	Operation Warning Label	12-00106
5	1	Mobile Containerramp Operating Instructions Label	12-00103
6	2	Approach Ramp Area Label	12-00104
7	1	Safety Stripping Kit	12-00099
8	1	Pump Warning Label	12-00105

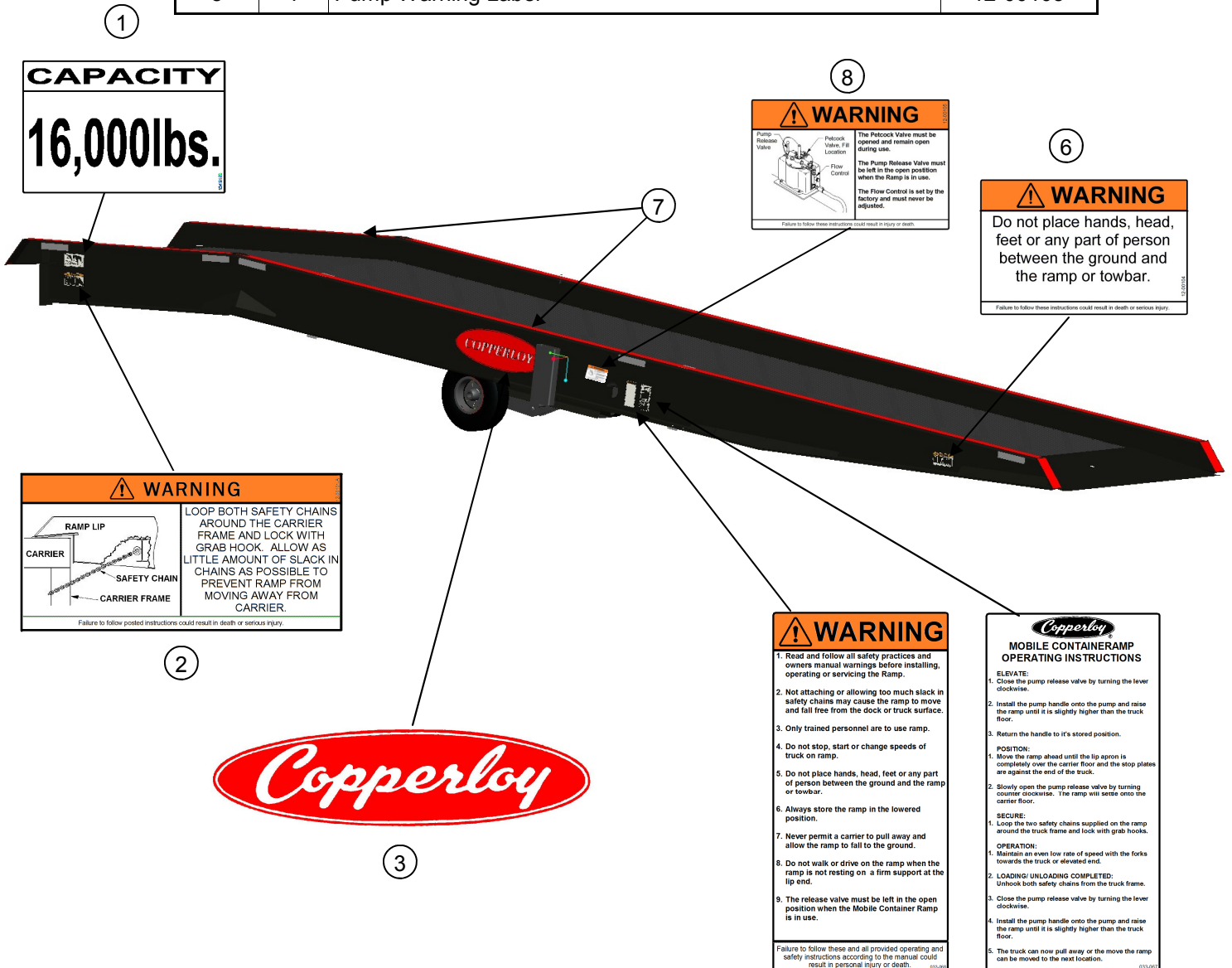

DOCK TO GROUND SAFETY LABELS

ITEM NO	QTY.	DESCRIPTION	PART NO.
1	2	Capacity Label	12-00102
2	2	Safety Chain Warning Label	12-00100
3	2	Copperloy Logo Label	
4	2	Approach Ramp Area Label	12-00104
5	1	Safety Stripping Kit	12-00099

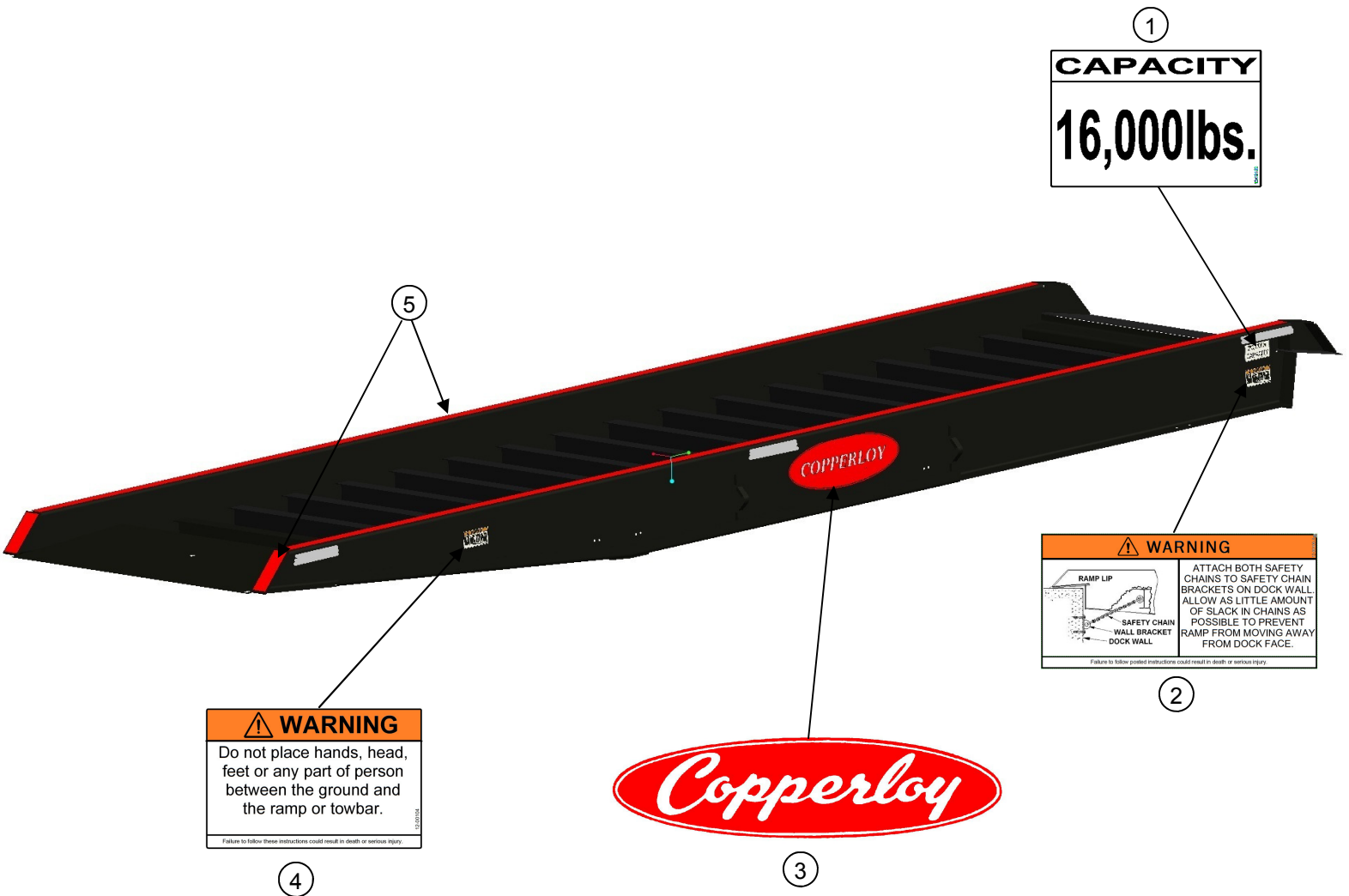



www.copperloy.com/loading-dock-equipment/yard-ramps/



JH Industries, Inc.
1981 E. Aurora Road
Twinsburg, OH 44087

Phone: 1-330-963-4105

Fax: 1-330-963-4111

Toll Free: 1-800-321-4968

www.copperloy.com