

EDGE-OF-DOCK

SEL Series

Installation

&

Owner's Manual

Serial No. 75652 to Present

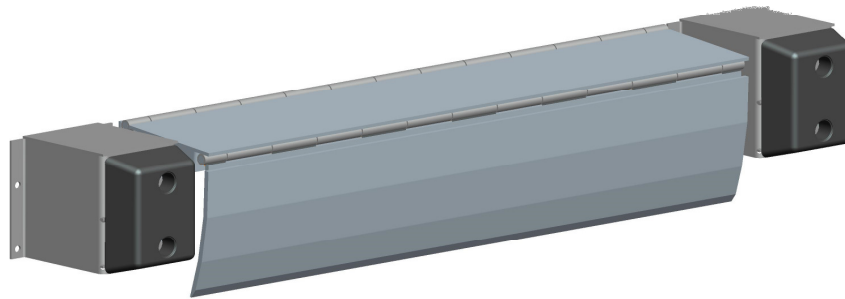

by
JH INDUSTRIES, INC.

Model # _____
Serial # _____
Date: _____

1981 E. Aurora, Rd.
Twinsburg, Ohio 44087
(330) 963-4105 (Phone)
1-800-321-4968 (Toll Free)
www.copperloy.com

⚠ WARNING

Do not install, operate or service this product unless you have read and understand the Safety Practices, Warnings, Installation and Operating Instructions contained in this manual. Failure to do so could result in serious injury or death.



WARRANTY

ALL WARRANTY CLAIMS MUST HAVE PRE-APPROVED RATES, TIMES AND AUTHORIZATION NUMBERS PRIOR TO ANY FIELD WORK, IN ORDER TO BE ACCEPTED BY JH INDUSTRIES, INC.

J H Industries, Inc. expressly warrants that any EDGE-OF-DOCK sold by it will be free from defects in material and workmanship under normal use for a period of one (1) year from the earlier of, 1) sixty (60) days after the date of shipment, or 2) the date of installation of the EDGE-OF-DOCK by the original purchaser, provided the purchaser maintains and operates the EDGE-OF-DOCK in accordance with the Owners Manual.

In the event that the EDGE-OF-DOCK proves to be defective in materials or manufacturing workmanship within the applicable period, J H Industries, Inc. will, at its option:

1. Replace the EDGE-OF-DOCK or the defective portion thereof without charge to the purchaser, or
2. Alter or repair the EDGE-OF-DOCK, on site or elsewhere, without charge to the purchaser.

This warranty IS EXCLUSIVE AND IS IN LIEU OF ALL GUARANTEES AND WARRANTIES, EXPRESSED OR IMPLIED BY ANYONE OTHER THAN J H Industries, Inc. sole warranty obligation shall be as set forth above.

The warranty does not cover any failure caused by improper installation, abuse, misapplication, overloading, negligence, or failure to lubricate and adjust the EDGE-OF-DOCK properly. Parts requiring replacement due to damage resulting from vehicle impact, abuse, improper operation or lack of proper protection are not covered by this warranty. Seller assumes no responsibility or liability for (1) consequential damages of any kind which result from the use or misuse of the EDGE-OF-DOCK; (2) damage or failure resulting from the use of unauthorized replacement parts or modification to the EDGE-OF-DOCK; (3) damage resulting from the misuse of the EDGE-OF-DOCK. THERE ARE NO WARRANTIES, EXPRESSED OR IMPLIED, WHICH EXTEND BEYOND THE DESCRIPTION ABOVE. THERE IS NO WARRANTY OF MERCHANTABILITY OR OF FITNESS FOR A PARTICULAR PURPOSE.

J H Industries, Inc. warranties extend only to the product itself.

J H Industries, Inc. DISCLAIMS all liability arising out of the workmanship, methods and materials used by the installer.

J H Industries, Inc. DISCLAIMS all liability for premature wear, product failure, property damage or bodily injury arising from improper installation or maintenance.

WARRANTIES, whether expressed or implied, relating to workmanship and materials used in connection with the installation of J H Industries, Inc. products are specifically DISCLAIMED.

INTRODUCTION

Welcome, and thank you for purchasing your dock leveler from Copperloy by JH Industries. It is designed to give you years of trouble-free operation.

This manual contains information that is needed to operate and maintain the leveler safely. It also contains a complete parts list and information about ordering replacement parts. Please read completely before using your new leveler.

This manual also contains a complete parts list and information about ordering replacement parts. JH Industries, Inc. has selected components for best fit and function for each of our products, therefore replacement parts should be identical to original equipment or have written approval for non-original equipment. **JH Industries, Inc. will not be responsible for equipment failures due to incorrect or non-approved replacement parts.**

**Verify that this is the most current Installation, Operation and Service Manuals.
To obtain an updated version please contact:**

JH Industries Inc.

1981 E. Aurora Rd.

Twinsburg, Ohio 44087

(330) 963-4105 (Phone) or 1-800-321-4968 (toll free)

Or visit our website under EOD SEL to download and print an up to date version.

TABLE OF CONTENTS

WARRANTY.....	3	HYDRAULIC SCHEMATIC.....	33
INTRODUCTION.....	3	SINGLE PHASE 120VAC	
TABLE OF CONTENTS.....	4	ELECTRICAL SCHEMATIC.....	35
SAFETY.....	4	1-PHASE 120VAC	
SAFETY PRACTICES.....	5-6	ENCLOSURE ASSEMBLY.....	35
GRADE CHART.....	6	SINGLE PHASE 230VAC	
CAPACITY.....	7	ELECTRICAL SCHEMATIC.....	36
OWNER'S RESPONSIBILITIES...	8	PARTS 1-PHASE PARTS.....	37
INSTALLATION.....	8-12	1-PHASE INSTALLED	
GENERAL INSTALLATION.....	13-15	ASSEMBLY.....	38
HYDRAULIC INSTALLATION.....	15-18	PARTS 3-PHASE ELECTRICAL	
OPERATION.....	19-22	SCHEMATIC.....	39
MAINTENANCE.....	23-26	PARTS 3-PHASE ENCLOSURE	
TROUBLE SHOOTING.....	27	ASSEMBLY.....	40
STANDARD PARTS LIST.....	28	3-PHASE INSTALLED	
INBOARD HANDLE PARTS LIST.....	29	ASSEMBLY.....	41
STANDARD BUMPER PARTS...	30		
OPTIONAL BUMPER PARTS.....	30		
LABEL PARTS LIST.....	31-32		

SAFETY

A product safety sign or label should alert persons to a specific hazard, the degree or level of hazard seriousness, the probable consequence of involvement with the hazard, and how the hazard can be avoided. **SIGNAL WORD** is a word or words that designate a degree or level of hazard seriousness. The signal words for product safety signs are “**DANGER, WARNING, CAUTION**” and “**NOTICE**”. Below is each of these signal words along with their definitions as directly referenced from *ANSI Z535.4-1998*.

DANGER

Indicates an imminently hazardous situation which, if not avoided, will result in death or serious injury. This signal word is to be limited to the most extreme situations.

WARNING

Indicates a potentially hazardous situation which, if not avoided, could result in death or serious injury.

CAUTION

Indicates a potentially hazardous situation which, if not avoided, may result in minor or moderate injury. It may also be used to alert against unsafe practices.

NOTICE!

“NOTICE” is the preferred signal word to address practices not related to personal injury. The safety alert symbol shall not be used with this signal word. As an alternative to “NOTICE”, the word “CAUTION” without the safety alert symbol may be used to indicate a message not related to personal injury.

SAFETY PRACTICES

WARNING

Read and follow all safety practices, placards and owners manual warnings before installing, operating or servicing the Dockleveler. Failure to follow the information provided could result in death or serious injury.

Before doing any maintenance or repair on the dock leveler **SECURE WITH THE MAINTENANCE STRUT**. See Fig. 23 & 24.

If you do not understand the instructions or if you have any problems or questions using or operating the dock leveler, contact your supervisor or the factory for assistance.

OPERATION

ONLY trained personnel are to operate or service dockleveler. Follow procedure on placards posted near dock leveler. Call factory for replacement placards, warning labels, or owner's manual.

ALWAYS before activating dock leveler:

- Ensure trailer is backed in against bumpers.
- Remove any end loads if required.
- Check trailer alignment to avoid lip interference. If lip does not lower to trailer bed, reposition vehicle.
- Chock truck wheels or lock truck in place with a truck restraining device and set brakes.

ALWAYS before allowing vehicle to leave the dock:

- Ensure that no equipment, material or people are on the dock leveler.
- Return the dock leveler to its stored position at dock level.

NEVER exceed 5 mph when driving on leveler.

NEVER exceed the rated capacity of the leveler.

NEVER travel on leveler unless lip is securely on truck floor. Visually check that the lip is supported by the truck bed and has a minimum of 4" of overlap onto the truck bed.

NEVER travel on the bumper blocks or over the edges of the leveler.

DO NOT operate the dockleveler with equipment, material, or people on or in the path of the ramp or lip.

DO NOT operate the dockleveler when anyone is in front of it.

DO NOT attempt to lift or lower the dockleveler ramp or lip by any means other than that described in the operation procedures contained in this manual. Keep hands and feet clear of the hinges at all times and maintain a safe distance from the underside of the leveler while raising or lowering.

NEVER stand in the driveway between the dockleveler and a backing truck.

DO NOT use this unit to service trailers outside its intended working range, which is 5" above and 5" below dock height. Verify with the manufacturers of all equipment to be used on your specific edge-of-dock leveler, to ensure that operating equipment at all specified grades are within safe operation. Do not operate any equipment that will not safely operate at any of the grades shown on page 4 at either ramp or lip.

Many trailers have air ride suspensions that may cause the trailer to move away from the dock during loading and unloading operations (commonly referred to as dock or trailer walk). The potential for dock walk caused by air ride suspensions may be reduced by exhausting or "dumping" the air from the air ride suspension system before servicing the trailer.

DO NOT USE THE DOCKLEVELER if it looks broken or does not seem to operate properly. Tell your supervisor it needs repair right away.

DO NOT operate the dockleveler if operation causes undue physical strain or if physical impairments could lead to undue strain in back, muscles, limbs, or joints.

ALWAYS keep both hands firmly on the hand leveler while raising or lowering the dockleveler. Keep other body parts clear of hand lever travel path while raising or lowering the dockleveler.

SAFETY PRACTICES, CONTINUED

INSTALLATION, MAINTENANCE AND SERVICE

Place barricades on the dock floor around the dock leveler final location and in the driveway in front of the dock leveler final location while installing, maintaining or repairing the dock leveler.

PUT THE MAINTENANCE STRUT IN PLACE before doing any maintenance or repair under the dock leveler. (See *Maintenance* pages 23-27)

When working on any electrical units, after raising, disconnect the power and properly tag or lock out before doing any maintenance or repair under the dock lever.

All electrical troubleshooting or repair must be done by a qualified technician and must meet applicable codes.

If it is necessary to make troubleshooting checks inside the control box with the power on, USE **EXTREME CAUTION!** Do not place fingers or un-insulated tools inside the control box. Touching wires or other parts inside the control box could result in electrical shock, death or serious injury.

EOD GRADE CHART

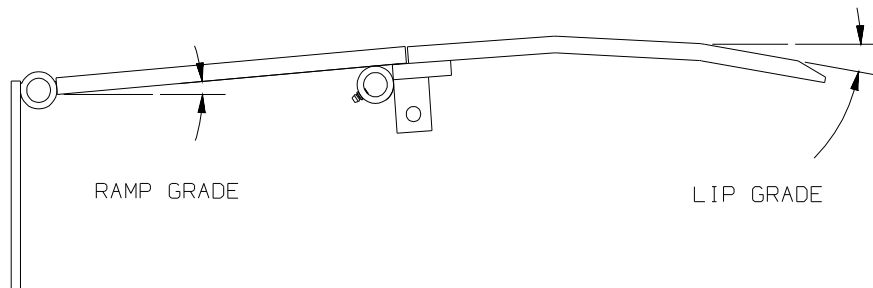

Truck Bed Position from		EOD Grade (%)	
		RAMP	LIP
ABOVE DOCK	5.0	28.3	3.1
	4.5	26.4	1.4
	4.0	24.5	-0.4
	3.5	22.7	-2.1
	3.0	20.8	-3.9
	2.5	19.0	-5.6
	2.0	17.2	-7.4
	1.5	15.4	-9.2
	1.0	13.6	-11.0
	0.5	11.8	-12.7
0.0	10.0	-14.4	

Truck Bed Position from		EOD Grade (%)	
		RAMP	LIP
BELOW DOCK	0.0	10.0	-14.4
	0.5	8.3	-16.3
	1.0	6.5	-18.1
	1.5	4.8	-19.9
	2.0	3.0	-21.8
	2.5	1.2	-23.6
	3.0	-0.5	-25.5
	3.5	-2.3	-27.4
	4.0	-4.0	-29.3
	4.5	-5.8	-31.2
5.0	-7.5	-33.1	

FIGURE 1- EOD Grade Chart

⚠ WARNING

Verify with the manufacturers of all equipment to be used on your specific edge-of-dock leveler, to ensure that operating equipment at all specified grades are within safe operation. Do not operate

any equipment that will not safely operate at any of the grades shown. Failure to do so could result in death or serious injury.

CALCULATING CAPACITY

Determining required leveler capacity: Determine gross vehicle weight (GVW = lift truck weight + battery + heaviest load) of the largest lift truck to be used. The (GVW x 1.5) = the minimum leveler capacity for normal use. However, if any one of the following condition below exists, multiply the (GVW x 2.1) to determine the minimum leveler capacity. If two or more of these conditions exists multiply the (GVW x 2.55). If a three-wheeled fork truck is to be used a 30,000# capacity Edge of Dock is recommended, unless the GVW multiplied by the factors requires a higher capacity. (Refer to Figure 2 for reference)

More than 8 trucks serviced per day

Three-Wheeled fork trucks (14,000# GVW or less)

Fork trucks travel faster than 3-mph

Fork trucks have front-end attachments or side shifters



Do not exceed dockleveler capacity. Over loading dockleveler could result in death or serious injury.

CONDITIONS

GVW	No Conditions apply	1 Condition Applies	2 Conditions Apply	3 Conditions Apply	4 Conditions Apply
1000	1500	2100	2550	2550	2550
2000	3000	4200	5100	5100	5100
3000	4500	6300	7650	7650	7650
4000	6000	8400	10200	10200	10200
5000	7500	10500	12750	12750	12750
6000	9000	12600	15300	15300	15300
7000	10500	14700	17850	17850	17850
8000	12000	16800	20400	20400	20400
9000	13500	18900	22950	22950	22950
10000	15000	21000	25500	25500	25500
11000	16500	23100	28050	28050	28050
12000	18000	25200			
13000	19500	27300			
14000	21000	29400			
15000	22500				
16000	24000				
17000	25500				
18000	27000				
19000	28500				
20000	30000				
21000					
22000					
23000					
24000					
25000					

FIGURE 2- Capacity Chart

Areas shown in gray require a 30,000lb capacity EOD
 Areas shown in black there are no options available in the EOD line
 All other areas require a min. of a 20,000lb capacity EOD
 Use as reference only some applications may vary.

OWNER'S RESPONSIBILITIES

The owner's responsibilities include the following:

The owner should recognize the inherent danger of the interface between dock and transport vehicle. The owner should, therefore, train and instruct operators in the safe use of dock leveling devices.

When a transport vehicle is positioned as closely as practicable to a dock leveling device, there shall be at least 4" of overlap between the front edge of the lip and the edge of the floor or sill of the transport vehicle. (See *Figure 20*)

The owner shall see that all nameplates, caution and instruction markings or labels are in place and that the appropriate operating and maintenance manuals are provided to users and shall not be obscured from the view of operating or maintenance personnel for whom such warnings are intended.

Manufacturer's recommended periodic maintenance and inspection procedures in effect at date of shipment shall be followed, and written records of the performance of these procedures should be kept.

Dock leveling devices that are structurally damaged or have experienced a sudden loss of support while under load, such as might occur when a transport vehicle is pulled out from under the dock leveling device, shall be removed from service, inspected by the manufacturer's authorized representative, and repaired as needed before being placed back in service.

Modifications or alterations of dock leveling devices shall be made only with written permission of the original manufacturer.

When industrial vehicles are driven on and off transport vehicles during the loading and unloading operation, the brakes on the transport vehicle shall be applied and wheel chocks or positive restraints that provide the equivalent protection of wheel chocks engaged.

The dock leveler should never be used outside its vertical working range or vertical lifting range or outside the manufacturer's labeled rated capacity. See Capacity Section (Page 7). It must also be compatible with the loading equipment and other conditions relating to the dock.

INSTALLATION

DOCK MOUNTING STEEL REQUIREMENTS

WARNING

Before installing the dockleveler, read and follow Safety Practices on pages 5 & 6.

ALWAYS place barricades around dockleveler on dock floor and drive while installing, maintaining or repairing dockleveler. Failure to do so could result in death or serious injury.

1. The face of the dock must be equipped with a minimum of 8" channel with anchor straps on 10" centers. Mounting on curb angle alone is NOT recommended.
2. There are four main mounting methods: installation with curb channel, flat transition

plate, formed angle, and steel approach ramp. Follow the section that addresses your installation and then continue to the GENERAL INSTALLATION section on pages 13 & 14 of this manual.

INSTALLATION WITH CURB CHANNEL

1. If curb channel is not already present, position it as shown in (*Figure 3*). Pour concrete.
2. Position the dockleveler in place.
3. Proceed to GENERAL INSTALLATION section on pages 13 & 14 of this manual.

INSTALLATION, CONTINUED

INSTALLATION WITH FLAT TRANSITION PLATE

1. Lay the transition plate on top of dock.
2. If using a beveled transition plate (Model: TPBF12) position transition plate flush with the front of dock edge and skip to step 6. (See Figure 4).
3. If using a kinked transition plate (Model: TPKF12) position transition plate flush with the front of dock edge and mark location of back of transition plate on floor of dock. (See Figure 5).
4. Slide transition plate forward 2" and mark location of back of transition plate on floor of dock.
5. Remove transition plate and cut a groove in concrete 1/2" deep between lines marked in steps 3 & 4.
6. Tack weld transition plate to angle nosing in at least four places on 66" & 72" wide EOD's and six places on 78" & 84" EOD's.
7. Install anchor bolts in the transition plate. All anchor bolts to be a min. strength in shear of 10,000lbs. Force and a min. of 6,000lbs. Pull out strength in uncracked concrete. When bolts are tight in the concrete, remove nuts, cut bolts flush with top of transition plate, and plug weld bolts to plate.

WARNING

All anchor bolts must be installed in accordance with the manufacturer's instructions. Improper installation may result in death or serious injury.

Do not install anchor bolts in cracks or expansion joints in concrete. Installation in cracks or expansion joints may cause the anchors to come loose and pull out. Use of improperly installed anchor bolts may result in death or serious injury.

NOTICE!

All anchor bolts to be a min. strength in shear of 10,000lbs. Force and a min. of 6,000lbs. Pull out strength in uncracked concrete.

8. Proceed to GENERAL INSTALLATION section on pages 13 & 14 of this manual.

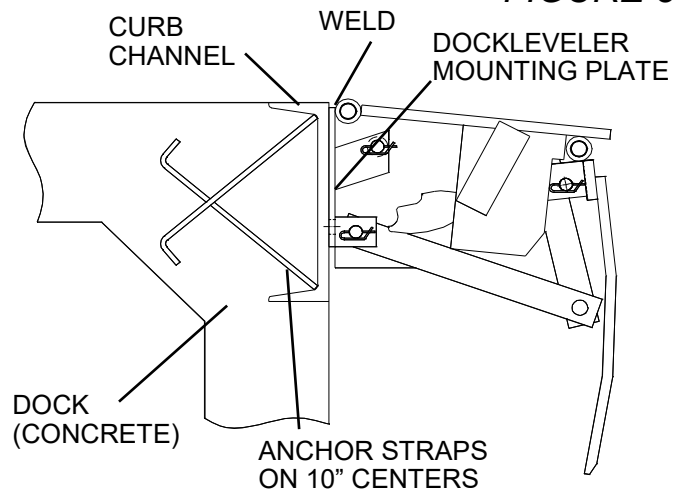
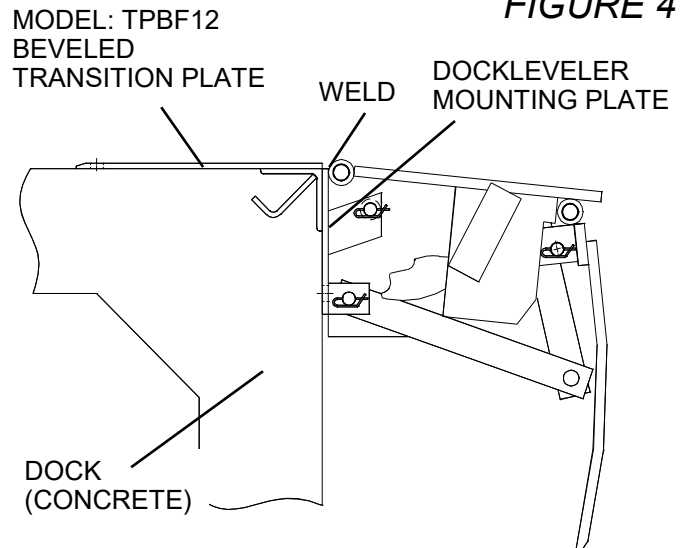
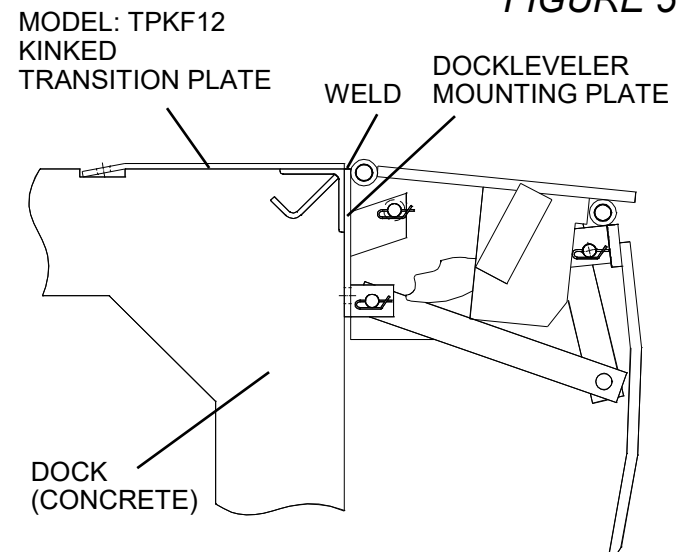
FIGURE 3

FIGURE 4

FIGURE 5

INSTALLATION, CONTINUED

INSTALLATION WITH FORMED ANGLE

1. Lay formed angle on top of dock.
2. If using a beveled formed angle (Model: TPBL24) position formed angle on dock making sure both legs are tight against top and face of dock and skip to step 7. (See Figure 6).
3. If using a kinked formed angle (Model: TPKL24) position formed angle in desired position on dock edge and mark location of back of angle on floor of dock. (See Figure 7).
4. Slide formed angle forward 2" and mark location of back of angle on floor of dock.
5. Remove angle and cut a groove in concrete 1/2" deep between lines marked in steps 3 & 4.
6. Place formed angle on dock making sure back edge of leg on top of dock is recessed in groove and both legs are tight against top and face of dock. Increase depth or width of groove as required.
7. Install anchor bolts in the formed angle. All anchor bolts to be a min. strength in shear of 10,000lbs. Force and a min. of 6,000lbs. Pull out strength in uncracked concrete. When bolts are tight in the concrete, remove nuts, cut bolts flush with top of formed angle and plug weld bolts to formed angle.

WARNING

All anchor bolts must be installed in accordance with the manufacturer's instructions. Improper installation may result in death or serious injury.

Do not install anchor bolts in cracks or expansion joints in concrete. Installation in cracks or expansion joints may cause the anchors to come loose and pull out. Use of improperly installed anchor bolts may result in death or serious injury.

NOTICE!

All anchor bolts to be a min. strength in shear of 10,000lbs. Force and a min. of 6,000lbs. Pull out strength in uncracked concrete.

8. Proceed to GENGERAL INSTALLATION section on pages 13 & 14 of this manual.

FIGURE 6

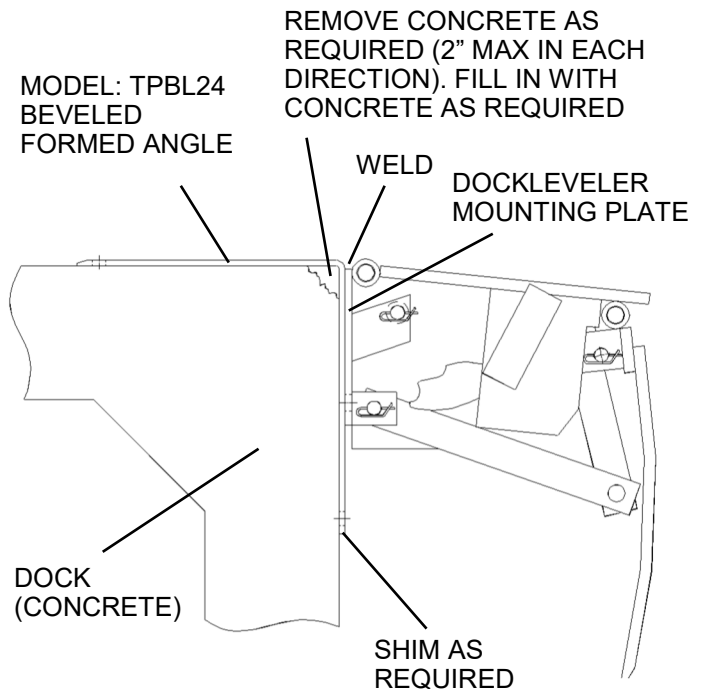
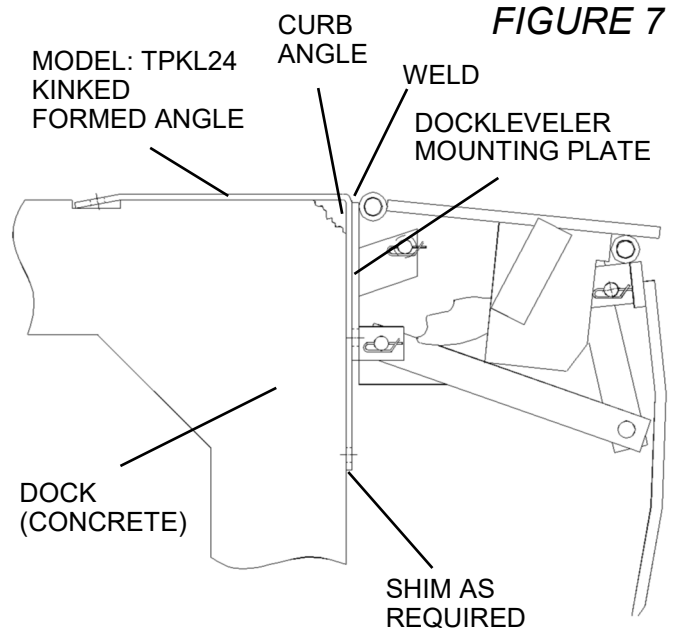

FIGURE 7



INSTALLATION, CONTINUED

INSTALLATION WITH STEEL APPROACH RAMP

1. Position the Steel Approach Ramp flush with the front face of dock. (See Figure 8).
2. Install anchor bolts in the steel approach ramp. All anchor bolts to be a min. strength in shear of 10,000lbs. Force and a min. of 6,000lbs. Pull out strength in uncracked concrete. When bolts are tight in the concrete, remove nuts, cut bolts flush with top of steel approach ramp and plug weld bolts to plate.

WARNING

All anchor bolts must be installed in accordance with the manufacturer's instructions. Improper installation may result in death or serious injury.

Do not install anchor bolts in cracks or expansion joints in concrete. Installation in cracks or expansion joints may cause the anchors to come loose and pull out. Use of improperly installed anchor bolts may result in death or serious injury.

NOTICE!

All anchor bolts to be a min. strength in shear of 10,000lbs. Force and a min. of 6,000lbs. Pull out strength in uncracked concrete.

3. Proceed to GENERAL INSTALLATION section on pages 13 & 14 of this manual.

FIGURE 8

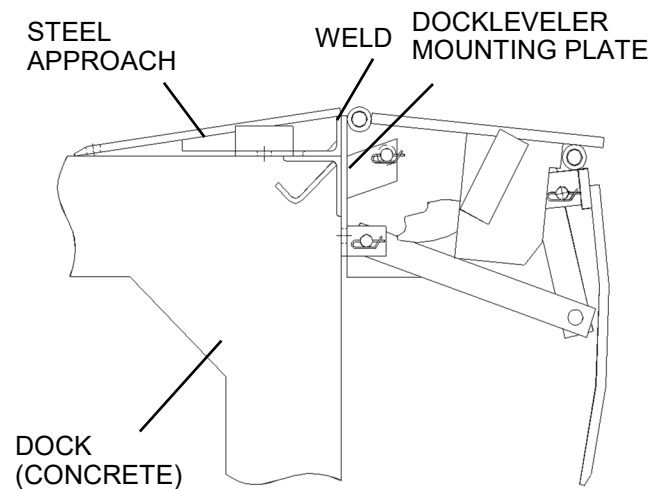

INSTALLATION, CONTINUED

INSTALLATION WITH RECESSED PIT

1. Use a minimum 12" x 13" pit recess with an additional 3" of clearance per side of leveler (See Figure 9 & 10).
2. Follow the section that addresses your installation and then continue to the GENERAL INSTALLATION section on pages 13 & 14 of this manual.

FIGURE 9

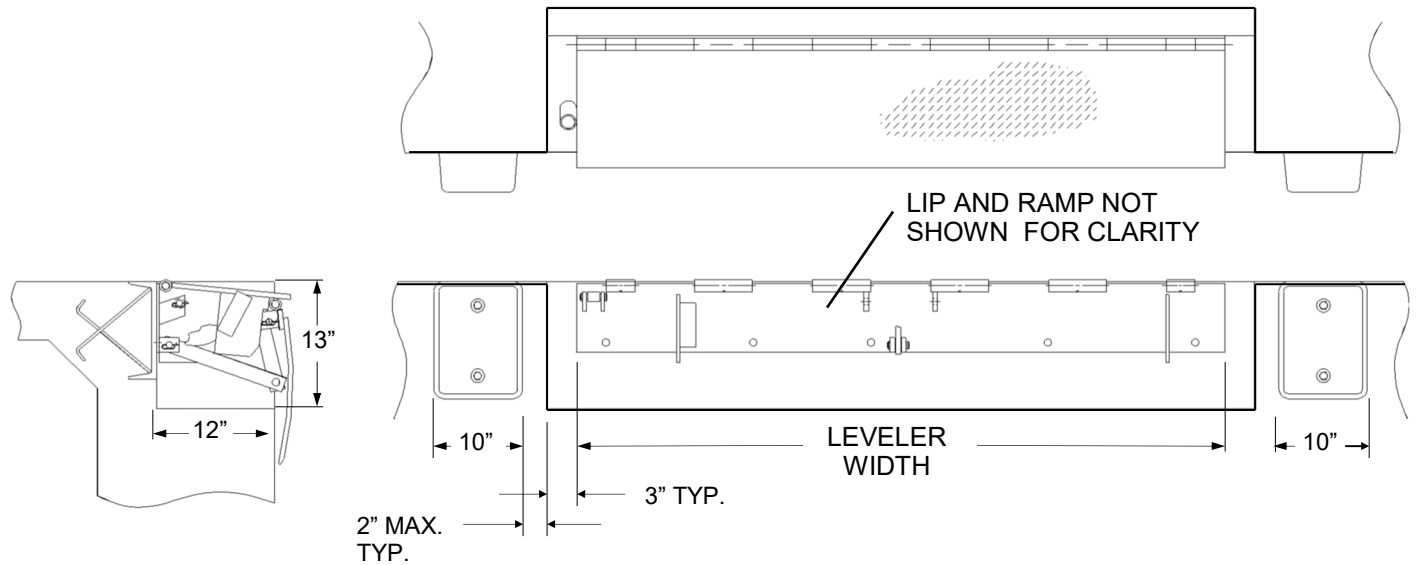

$$\text{PIT WIDTH} = (\text{LEVELER WIDTH}) + 3"$$

FIGURE 10

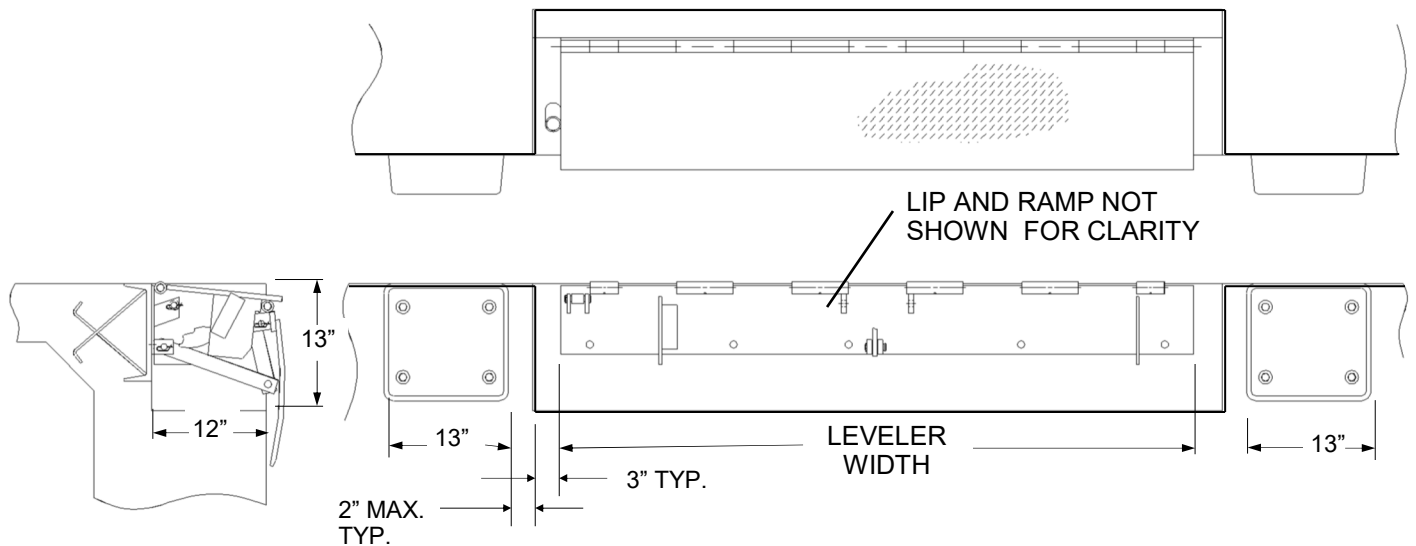

$$\text{PIT WIDTH} = (\text{LEVELER WIDTH}) + 3"$$

GENERAL INSTALLATION

⚠ WARNING

Read and follow Safety Practices on page 2. Failure to follow these safety practices could result in property damage, serious injury or death.

Installation should not be attempted by persons not familiar with equipment and techniques required for proper installation. Improper installation could result in property damage, serious injury or death.

1. Using a 1,000# minimum capacity plate clamp, clamp the lip plate at the center of the width. (See Figure 12).

⚠ WARNING

Inadequate lifting equipment or practices can cause a load to fall unexpectedly. Make sure the lifting chain or other lifting devices are in good condition and have a rated capacity of at least 1000 lbs. for the lifting angle used. Never allow anyone to stand on or near the dockleveler when it is lifted or placed onto the dock. Stand clear of the dockleveler when it is being placed onto the dock. Failure to follow this warning can allow the dockleveler to fall, tip, or swing into people, causing death or serious injury.

Follow plate clamp manufacturer's use instructions. Failure to follow plate clamp manufacturer's use instructions could result in property damage, death or serious injury.

2. Position dockleveler mounting plate centered on face of dock and 1/4" below top of curb channel, transition plate, angle plate or steel approach ramp. (See Figure 12).

NOTICE!

The dockleveler must be plumb to operate properly. Use shims or remove concrete as necessary to make the mounting plate plumb.

3. Weld two 2" welds at the upper outside edges of the mounting plate and plug weld the two outer holes in the mounting plate (if curb channel is not used install two 5/8" DIA. anchors).
4. Support dockleveler by inserting hand lever into lever socket located on right side of ramp plate. (See Figure 17).

5. While one person holds the hand lever down as shown in (Figure 18), with the use of the plate clamp, carefully lower lip to the full back position as shown in (Figure 18). Remove plate clamp.
6. Using the hand lever, carefully lower the dockleveler to the rest position as shown in (Figure 22). While lowering dockleveler to the rest position it is necessary to have another person use a pipe or similar device to hold the lip extender link disengaged as shown in (Figure 18). This will prevent the lip from extending out away from the dock.

⚠ WARNING

Do not use hands or feet to hold lip extender link disengaged. Use of hands or feet could cause a pinch point resulting in death or serious injury.

⚠ CAUTION

Failure to keep lip extender link disengaged while lowering dockleveler could result in damage to the link.

7. Weld four 1" long welds evenly spaced across the top edge of mounting plate to secure dockleveler.
8. With the hand lever, hinge the ramp to the upright position and back to rest position, checking for freeness to ramp and mounting plate hinge.

⚠ WARNING

Do not allow lip and ramp to fall free. Allowing the dockleveler to fall free could result in the dockleveler coming free from the dock or damaging linkage, resulting in property damage, serious injury and/or death.

Do not allow lip to extend out away from the dock before all welding and anchor installation is complete. Operating the dockleveler before all installation is complete could result in property damage, death or serious injury.

GENERAL INSTALLATION, CONTINUED

- Continuously weld dockleveler mounting plate to curb channel, transition plate, angle plate or steel approach ramp in accordance with AWS Standards.

NOTICE!

Use care when welding. Do not allow weld or weld spatter on the hinge tubes. Weld on the hinge tubes may interfere with normal operation of the dockleveler.

- Plug weld remaining anchor holes in mounting plate (if curb channel is not used, install remaining 5/8" DIA. anchors).
- Position bumper blocks and weld in place. (See Figure 11).
- Anchor bumpers with 5/8" DIA. anchors in holes provided.

WARNING

All anchor bolts must be installed in accordance with the manufacturer's instructions. Improper installation may result in serious personal injury or death.

Do not install anchor bolts in cracks or expansion joints in concrete. Installation in cracks or expansion joints may cause the anchors to come loose and pull out. Use of improperly installed anchor bolts may result in death or serious injury.

NOTICE!

All anchor bolt lengths must suit local codes and conditions. Type and depth of concrete will determine type and length of anchor bolts required.

- Clean away all debris and paint all welded joints.
- Raise the dockleveler and SECURE WITH THE MAINTENANCE STRUT. See (Figure 24 & 25).
- Adjust two extension springs to assist in lifting dockleveler from rest position. Check the amount of bolt exposed beyond the spring face. If the amount is the same the springs are adjusted evenly. Adjust as required.

WARNING

Do not over-adjust the extension springs. Over-adjusting extension springs may cause the dockleveler to bounce or float during use. Use of an over-adjusted dockleveler could result in death or serious injury.

- Once installed, on the front cover write in Model #, Serial # and Date Installed. By doing this you are agreeing to reading and following all safety practices, manuals and instructions provided.

FIGURE 11

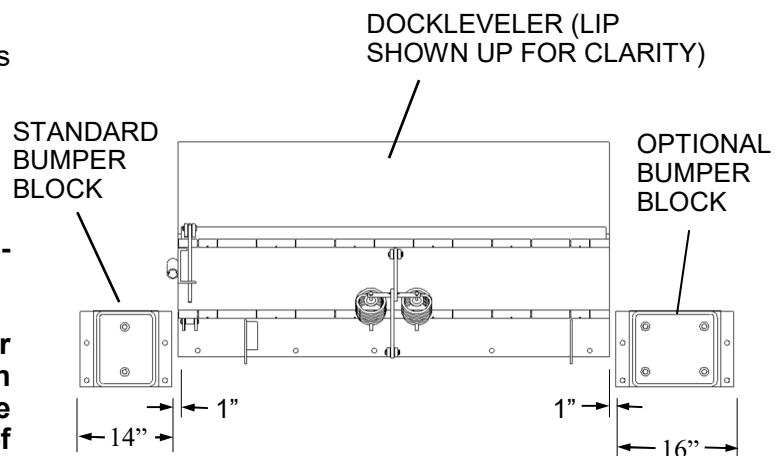
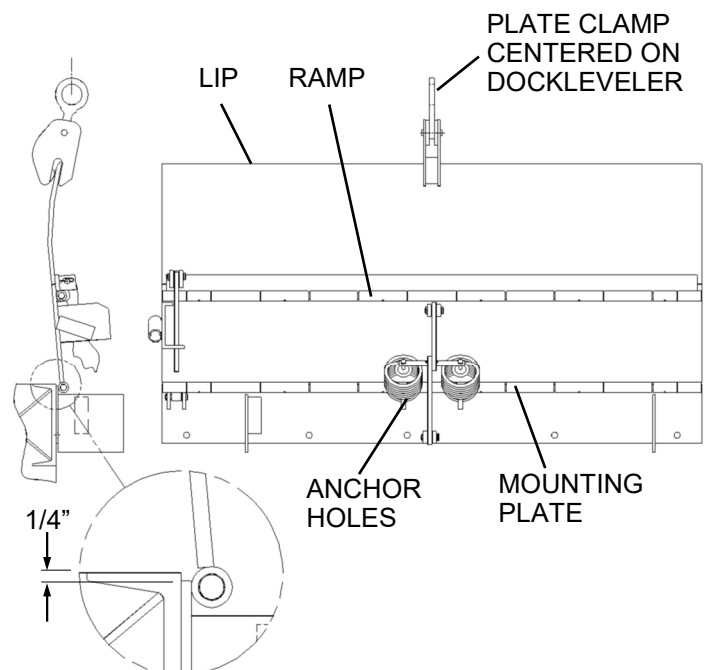

FIGURE 12



HYDRAULIC INSTALLATION

⚠ WARNING

Before installing the dockleveler, read and follow Safety Practices on pages 5 & 6.

Power to control box must be from a fused disconnect supplied by others. For correct fuse size refer to Wiring Diagram section of this manual. Before doing any electrical work, make certain the power is disconnected and properly tagged or locked out. All electrical work must be done by a qualified technician and must meet all applicable codes. If it is necessary to make trouble shooting checks inside the control box with the power on, **USE EXTREME CAUTION**. Do not place fingers or un-insulated tools inside the control box. Touching wires or other parts inside the control box could result in electrical shock, death or serious injury could occur.

Place barricades around pit on dock floor and drive while installing, maintaining or repairing dockleveler.

Do not remove any components of the Edge-of-Dock unless noted to in the installation instructions.

1. Install the dockleveler in place per standard Mechanical installation instructions.
2. Attach power unit mounting plate by butting to the bottom of the dockleveler mounting plate and flush with the edge of the plate as shown in (Figure 13).
3. Square and plumb the power unit mounting plate to the bottom edge of the dockleveler to ensure proper alignment.
4. Secure power unit mounting plate by butt welding to the dockleveler mounting plate and using the holes provided with 1/2" dia. anchors to suit.

NOTICE!

All anchor bolt lengths must suit local codes and conditions. Type and depth of concrete will determine type and length of anchor bolts required.

5. If retrofitting a power unit to an existing dockleveler, follow step #6 if not continue to step #7.

FIGURE 13

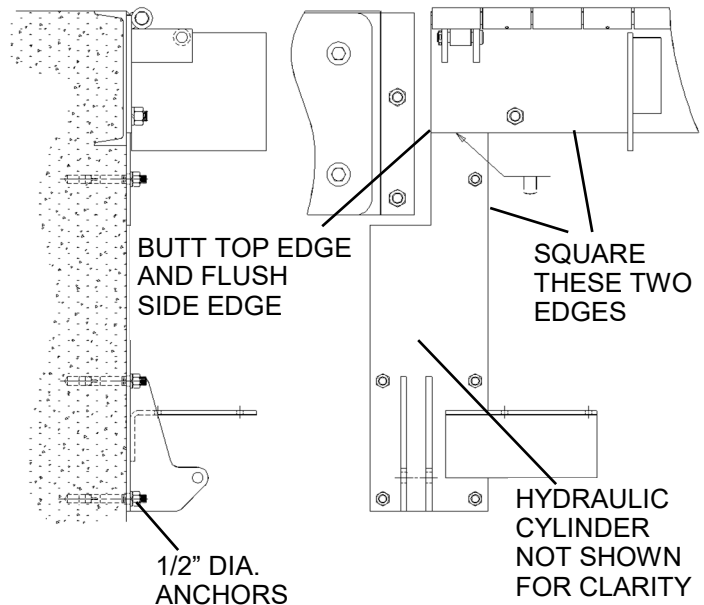
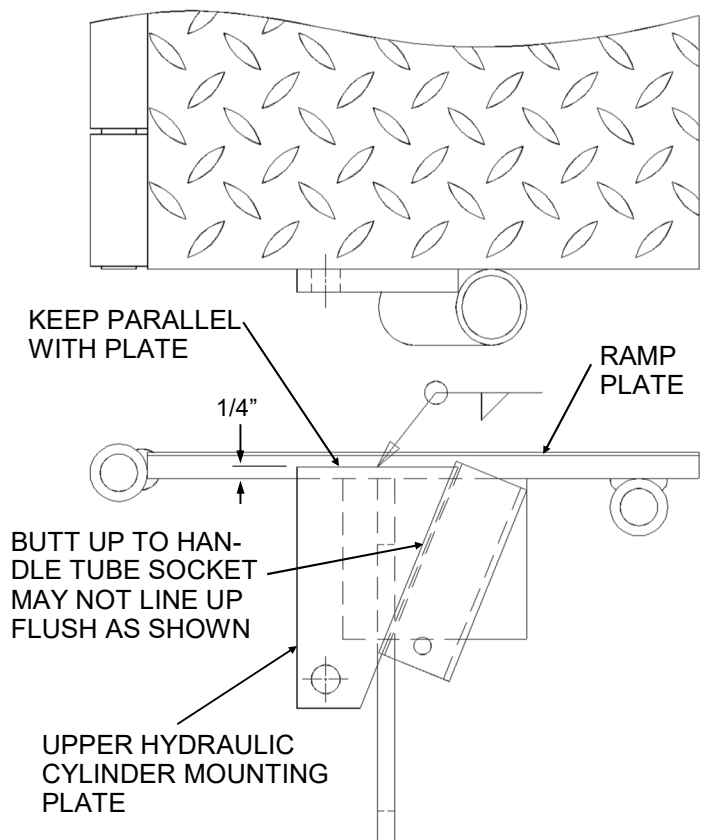

FIGURE 14



HYDRAULIC INSTALLATION, CONTINUED

HYDRAULIC CYLINDER CONNECTION

6. Locate and weld Hydraulic Cylinder upper mounting bracket to the dockleveler ramp plate as shown. (See Figure 14).
7. With the dockleveler in the rest position, adjust the hydraulic cylinder rod eye so that the rod eye hole center is about 3-1/2" from the unthreaded portion of the extension rod. Then extend the hydraulic cylinder until the rod eye lines up with the hole in the upper mounting bracket. Verify that the EOD ramp plate is resting on the mounting plate gussets. (See Figure 15).

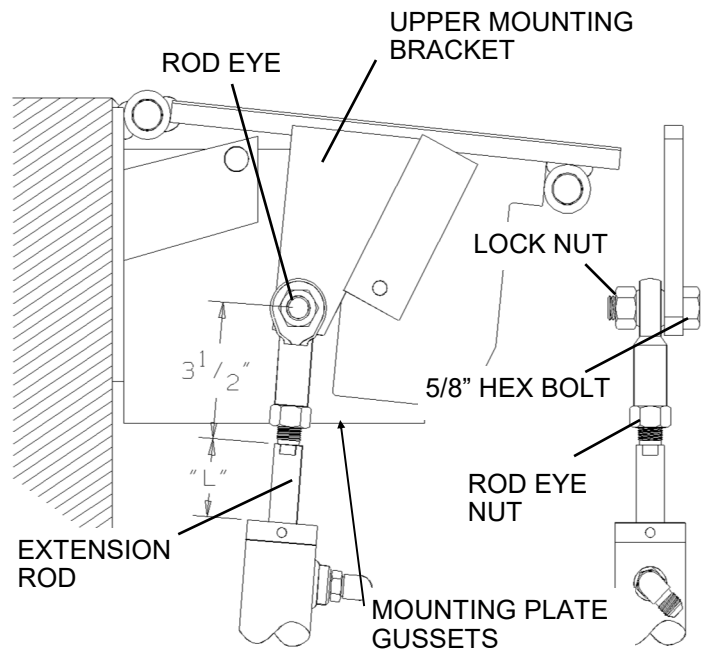
FIGURE 15

⚠ WARNING

Do not use fingers to check alignment, use bolt supplied. A pinch point could result in serious injury.

If electrical connections are completed prior to hydraulic cylinder adjustment, disconnect and lockout until all work is done. Failure to follow these safety practices could result in death or serious injury.

⚠ CAUTION

The "L" dimension (or minimum amount of exposed extension rod with the dockleveler in it's rest position.) must be greater than 1-3/4". Failure to do so will cause the hydraulic cylinder to bottom out under load resulting in permanent damage to the hydraulic cylinder.

8. Assemble and tighten 5/8" hex bolt and lock nut supplied. Then tighten the rod eye nut to secure rod eye. (See Figure 15).
9. Mount control box per local codes. Control box should be mounted inside the building, and give the operator a clear view of the dock during use.

⚠ WARNING

The control box must be mounted where the operator has a complete and clear view of the dock and EOD during operation. Failure to mount the Control Box in the correct area could result in personal injury or death.

10. Layout and install the electrical conduit refer to pg. 16 of this manual.
11. Supply and wire per schematics shown in this manual. Refer to pages 34-36 (1-Phase) & 39 (3-Phase) of this manual for schematics. Verify that all supplied equipment matches the Voltage and Phase of the supplied power. See pg. 16 for disconnect sizing, disconnect to be supplied by others.
12. Replace **RED** shipping plug with breather vent cap at tank of power pack. If running unit without vent cap in the tank port damage to unit could result.

HYDRAULIC INSTALLATION, CONTINUED

STANDARD 10"x13"x4" MOLDED BUMPER (2-Hole)

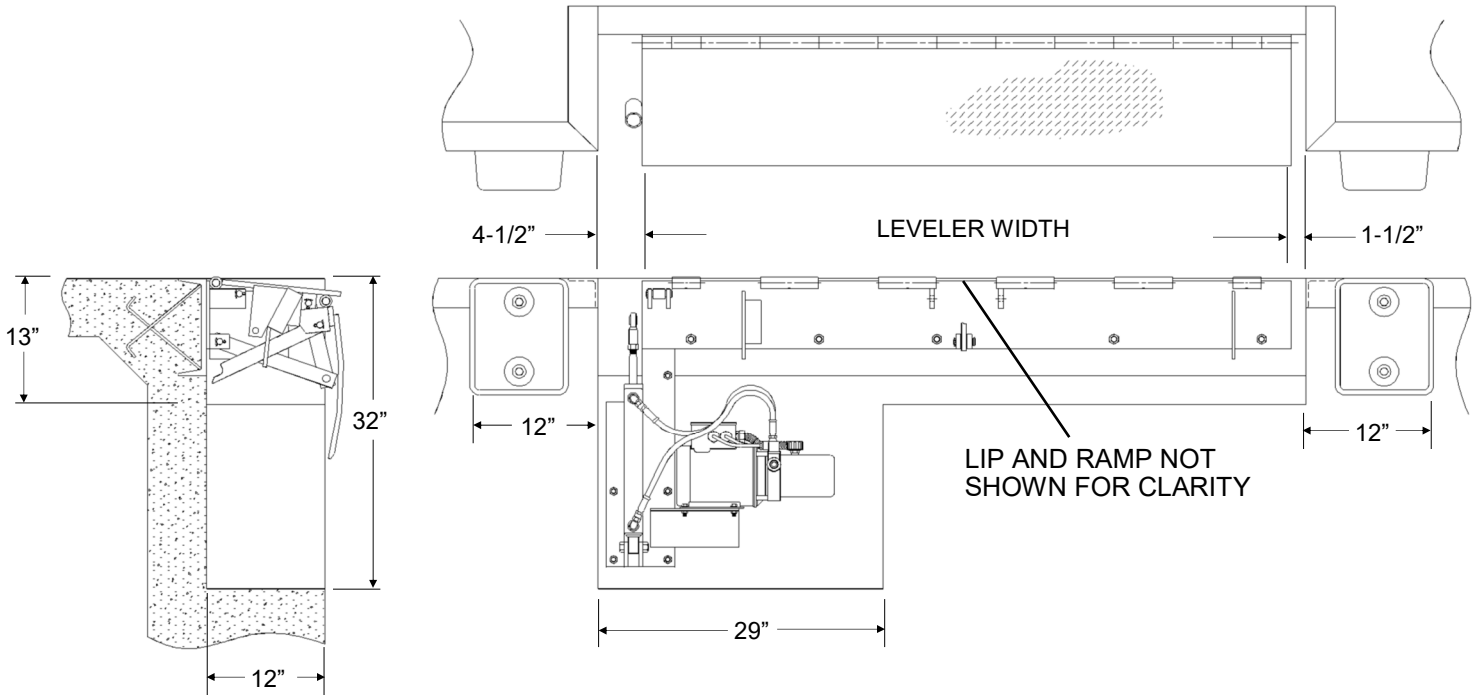

OPTIONAL 12"x13"x4" MOLDED BUMPER (4-Hole)

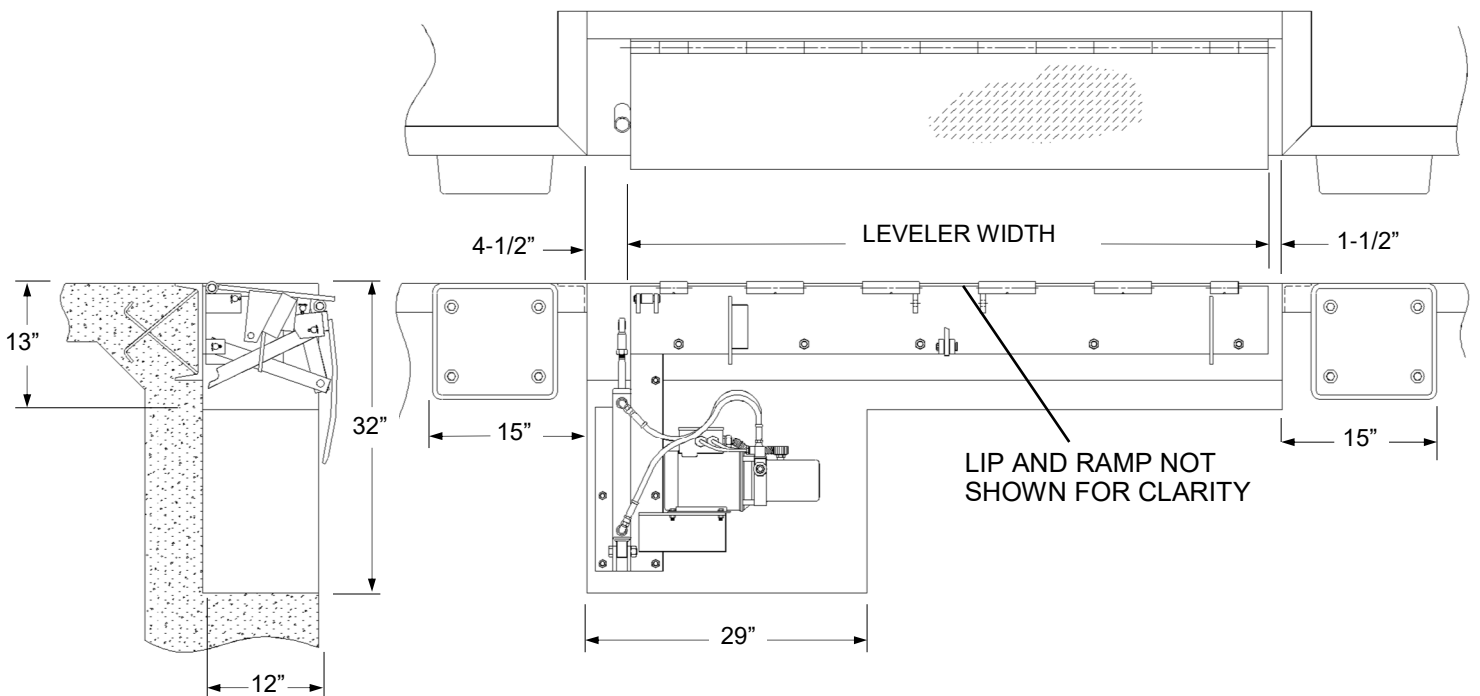

HYDRAULIC INSTALLATION, CONTINUED

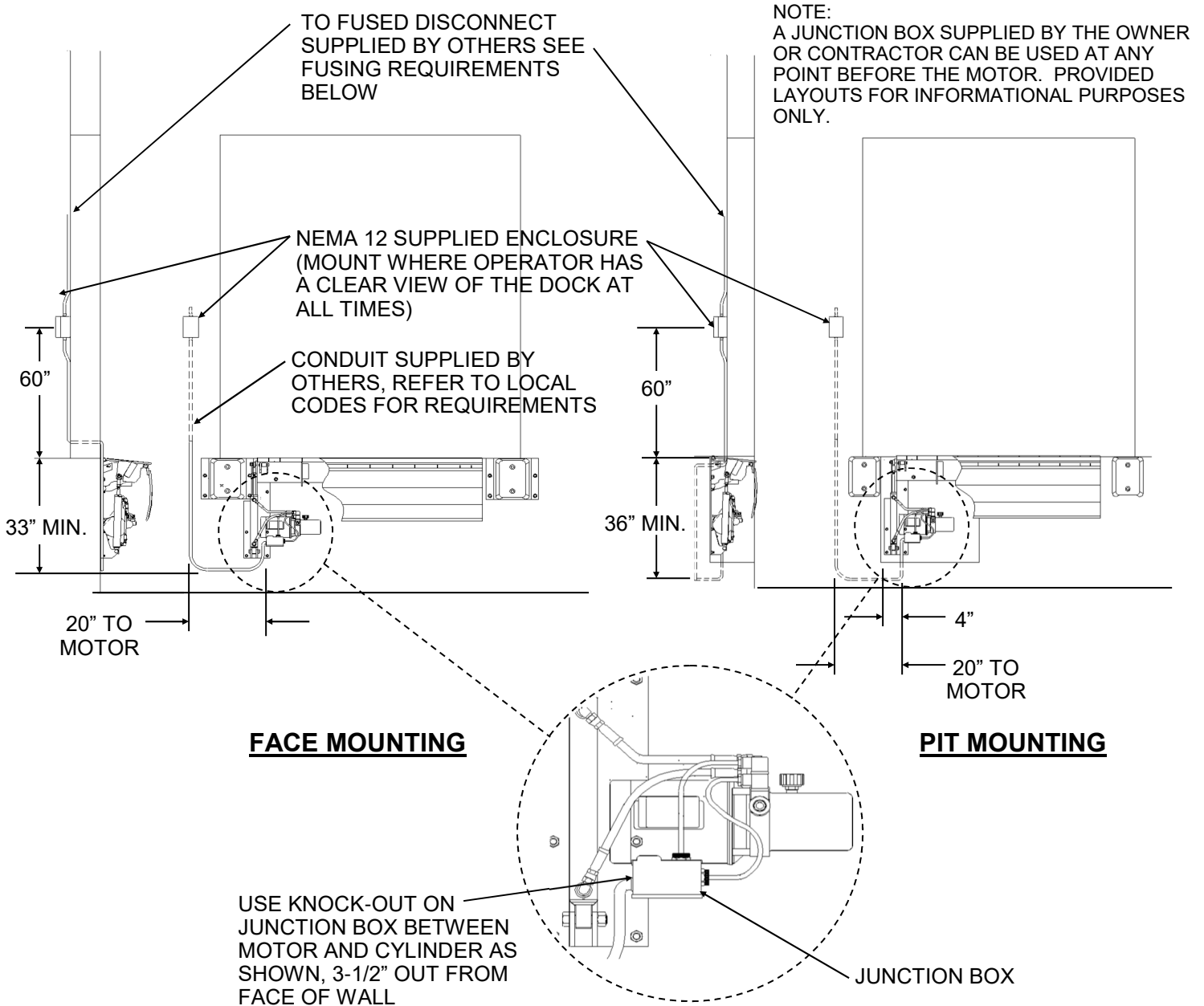

Voltage/Phase	Motor Full Load Amps (FLA)	Disconnect Fusing Requirements	Overload Setting
115VAC/1-Phase	13.6 Amps	20 Amps	13.6 Amps
230VAC/1-Phase	6.8 Amps	15 Amps	6.8 Amps
208-230VAC/3-Phase	3.7-3.4 Amps	10 Amps	3.7-3.4 Amps
460VAC/3-Phase	1.7 Amps	5 Amps	1.7 Amps

Notes:

1. All motors are 1 HP
2. Motor , Control Box, and Disconnect must be properly grounded.

⚠ WARNING

Before operating the dockleveler, read and follow Safety Practices on pages 5 & 6.

Use by untrained people could result in serious injury or death. Read and follow complete Operation instructions. **DO NOT USE THE DOCKLEVELER IF IT LOOKS BROKEN OR DOES NOT SEEM TO WORK RIGHT.** Tell your supervisor it needs repair.

Always be certain that the truck wheels are chocked, or that the truck is locked in place by a truck restraining device and the brakes are set, before loading or unloading. Trucks pulling away from the dock unexpectedly could result in death or serious injury.

Keep both hands firmly on the hand lever while raising or lowering the dockleveler. Keep other body parts clear of hand lever travel path while raising or lowering the dockleveler. Do not use legs or feet to move or hold hand lever. Failure to follow these and other provided warnings could result in death or serious injury.

Do not operate dockleveler if operation causes undue physical strain or if physical impairments could lead to undue strain in back, muscles, limbs, or joints.

⚠ CAUTION

To avoid damage to load and dockleveler do not activate unit if loads will be in way of extended lip. If the lip touches loads before resting on carrier floor, linkage must be disengaged. Use hand lever to hold 12" ramp plate in the full back position and with a pipe or similar device, disengage lip extender link from the extender bushing. Once disengaged, return unit to rest or pendant position.

INTRODUCTION

The Edge-of-Dock Dockleveler is designed to span and compensate for space and height differences between a loading dock and freight carrier to allow safe, efficient freight transfers.

The Mechanical Edge-of-Dock Dockleveler is spring counterbalanced. A hand lever is used to position the ramp and lip onto the truck bed and to return the dockleveler to the stored position.

Moving the hand lever back moves the ramp to the full raised position, engaging the lip extension link. Moving the lever forward extends the dockleveler lip onto the truck.

After loading, moving the hand lever moves the lip off the truck. The hand lever is then moved back to place the dockleveler back into stored position.

1. Wait until a truck is in position against the dock bumpers.
2. Tell truck driver " Your truck must stay at the dock."
3. Chock or hitch truck.
4. Remove end loads with the dockleveler in the stored position. (See Figure 16).

FIGURE 16

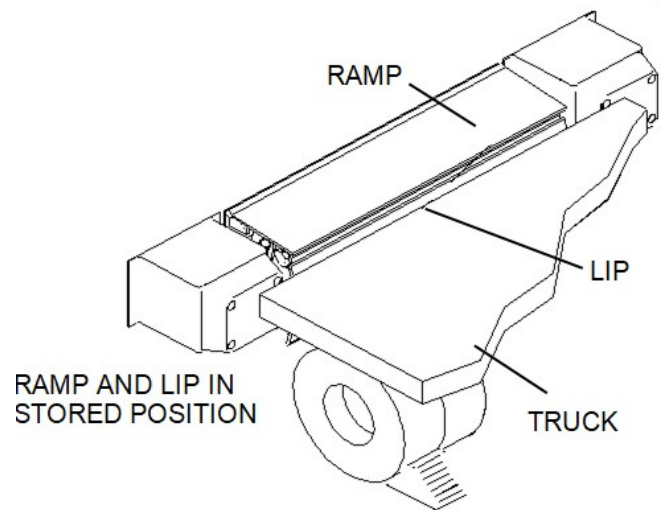

5. To extend the dockleveler lip into the truck:
 - 5.1 Insert hand lever into lever socket located on right side of ramp plate. (See Figure 17).

OPERATION, CONTINUED

FIGURE 17

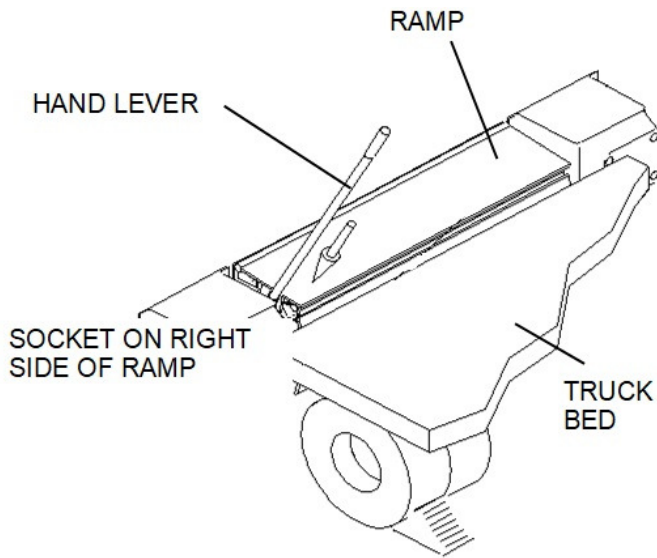
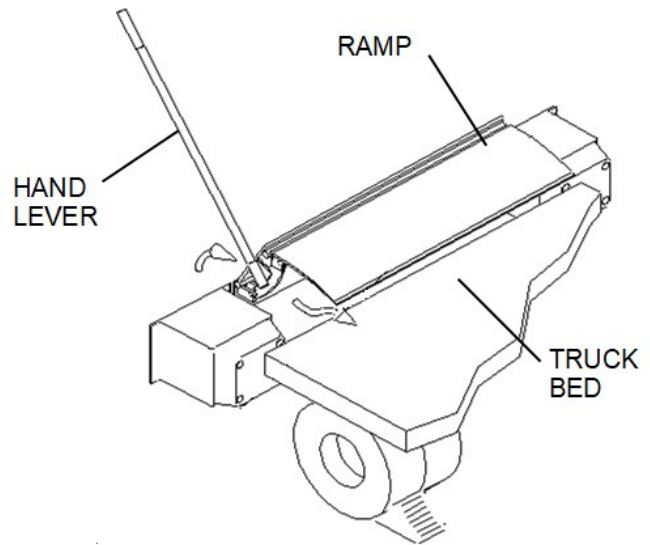

FIGURE 19



⚠ WARNING

Keep both hands firmly on the hand lever while raising or lowering the dockleveler. Keep other body parts clear of hand lever travel path while raising or lowering the dockleveler. Do not use legs or feet to move or hold hand lever.

- 5.2 Pull back on the hand lever until the lip extender link is properly seated on the extender pivot bushing. (See Figure 18).

- 5.4 Once dockleveler is resting securely on truck bed, remove hand lever. (See Figure 20).

FIGURE 20

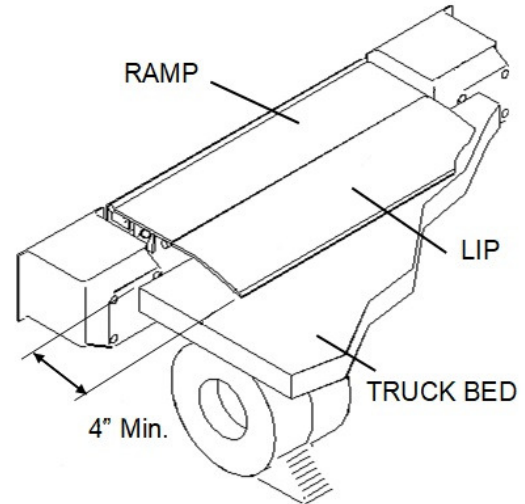
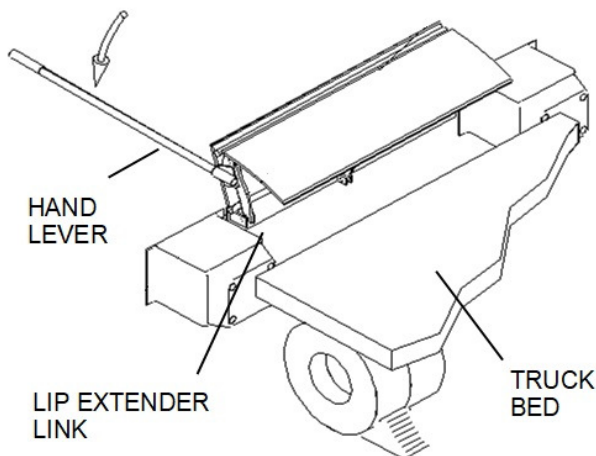

FIGURE 18



- 5.3 Raise hand lever. Lip will extend automatically as the ramp is lowered onto the truck bed. (See Figure 19).

⚠ WARNING

Do not operate the dockleveler when anyone is on or in front of it.

Stay clear of the dockleveler when it is moving.

Do not walk or drive on the dockleveler or lip until it is fully extended and supported by the truck bed.

OPERATION, CONTINUED

WARNING

Never use a fork truck or other material handling equipment to lower the ramp and lip section.

6. Proceed with loading or unloading.
7. Return the dockleveler to the stored position when entry to the truck is no longer required.
 - 7.1 Re-insert hand lever, into lever socket located on right side of ramp plate.

WARNING

Keep both hands firmly on the hand lever while raising or lowering the dockleveler. Keep other body parts clear of hand lever travel path while raising or lowering the dockleveler. Do not use legs or feet to move or hold hand lever.

- 7.2 Pull back on the hand lever until the lip clears the truck bed. (See Figure 21).

FIGURE 21

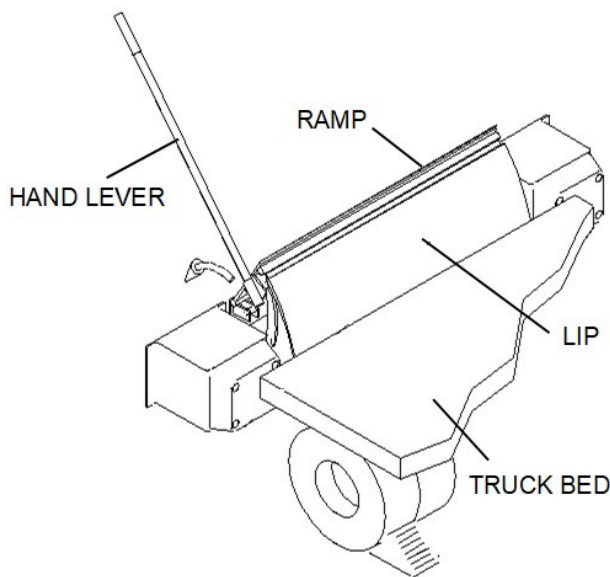

- 7.3 Raise hand lever and allow the ramp and lip to lower to their stored position. (See Figure 22).

FIGURE 22

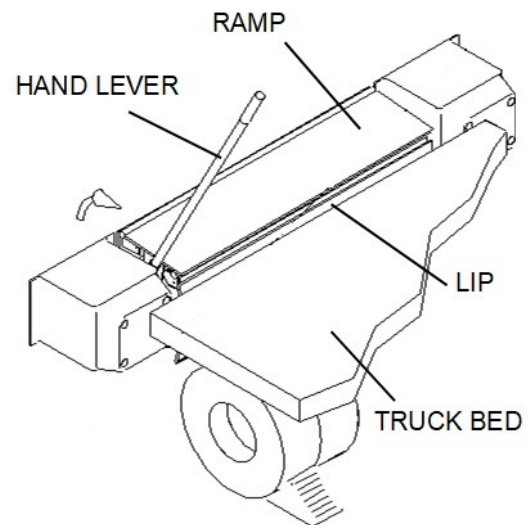

- 7.4 Remove hand lever.

8. Un-chock or release truck

WARNING

Do not allow the truck to leave before properly storing the dockleveler. If the truck pulls away from the dock before the dockleveler is stored, the lip will fall to the pendant position. You must use the hand lever to return the dockleveler to its dock level (stored) position. Failure to do so could result in death or serious injury.

9. Tell truck driver "Your truck may now leave the dock."

HYDRAULIC OPERATION

WARNING

Before operating the dockleveler, read and follow Safety Practices on page 5 & 6.

Use by untrained people could result in serious injury or death. Read and follow complete Operation instructions. **DO NOT USE THE DOCKLEVELER IF IT LOOKS BROKEN OR DOES NOT SEEM TO WORK RIGHT.** Tell your supervisor it needs repair.

Always be certain that the truck is locked in place by a truck restraining device and the brakes are set, before loading or unloading. Trucks pulling away from the dock unexpectedly could result in serious injury or death.

1. Wait until a truck is in position against the dock bumpers.
2. Tell truck driver "Your truck must stay at the dock."
3. Chock or hitch truck.
4. Remove end loads with the dockleveler in the stored position. (See Figure 16).
5. Push the "UP" button and hold until the dock lever raises and reaches full back position.
6. Push the "DOWN" button, the dockleveler will extend its lip and reach out onto the carrier floor. Hold the button until the ramp plate and the lip plate are pulled to an even surface.
7. Release the "DOWN" button. Verify that the lip of the Edge-of-Dock is supported by the carrier floor and that there is adequate overlap. (See figure 20)

WARNING

Do not operate the dockleveler when anyone is on or in front of it.

Stay clear of the dockleveler when it is moving.

Do not walk or drive on the dockleveler or lip until it is fully extended and supported (Min. 4")

by the truck bed.

Never use a fork truck or other material handling equipment to lower the ramp and lip section.

8. When done using the unit, push the "UP" button until the lip falls clear of the carrier floor then release the button, the lip and ramp will coast back down to the rest position.
9. Un-chock or release truck.

WARNING

Do not allow the truck to leave before properly storing the dockleveler. If the truck pulls away from the dock before the dockleveler is stored, the lip will fall to the pendant position. You must use the hand lever to return the dockleveler to its dock level (stored) position. Failure to do so could result in death or serious injury.

10. Tell truck driver "Your truck may now leave the dock."

CAUTION

Never use anything other than the hydraulic cylinder or handle to activate the dockleveler. If maintenance or servicing is required make sure to disconnect the hydraulic cylinder before moving to the maintenance position. Failure to do so could result in damage to the cylinder seals.

NOTICE!

The hydraulic cylinder and power pack will allow the cylinder to extend and retract with normal truck and dockleveler deflection.

⚠ WARNING

Before servicing the dockleveler, read and follow all Safety, Warnings and Manuals.

STAND CLEAR! The dockleveler moves toward you. Always be certain the ramp is in the raised position, **SECURED WITH THE MAINTENANCE STRUT** (See *Figure 24*) before servicing dockleveler. Failure to do so could result in death or serious injury.

Always return the dockleveler to stored position after service. Failure to do so could result in death or serious injury.

INSERT MAINTENANCE STRUT

1. Using the hand lever, position the dockleveler in the full back position. (See *Figure 18*).
2. While one person holds the hand lever down as shown in (*Figure 18*), another person standing on the drive surface must position the lip to its full upright position (*As shown in Figure 24*).
3. With the ramp and lip in the full upright position, move the hand lever to the maintenance socket location. (*As shown in Figure 24*).

REMOVE MAINTENANCE STRUT

1. With the ramp and lip in the full back position, move the hand lever back to the lever socket location. (*As shown in Figure 18*).
2. While one person holds the hand lever down, as shown in (*Figure 18*), another person standing on the drive surface must position the lip back down to the full back position (*As shown in Figure 18*).
3. Using the hand lever lower the dockleveler to the rest position as shown in (*Figure 16*). While lowering dockleveler to the rest position it is necessary to have another person use a pipe or similar device to hold the lip extender link from engaging on the extender pivot bushing (*As shown in Figure 23*), to prevent the lip from extending out away from the dock.

⚠ WARNING

Do not use hands or feet to hold lip extender link disengaged. Use of hands or feet could cause a pinch point resulting in death or serious injury.

FIGURE 23

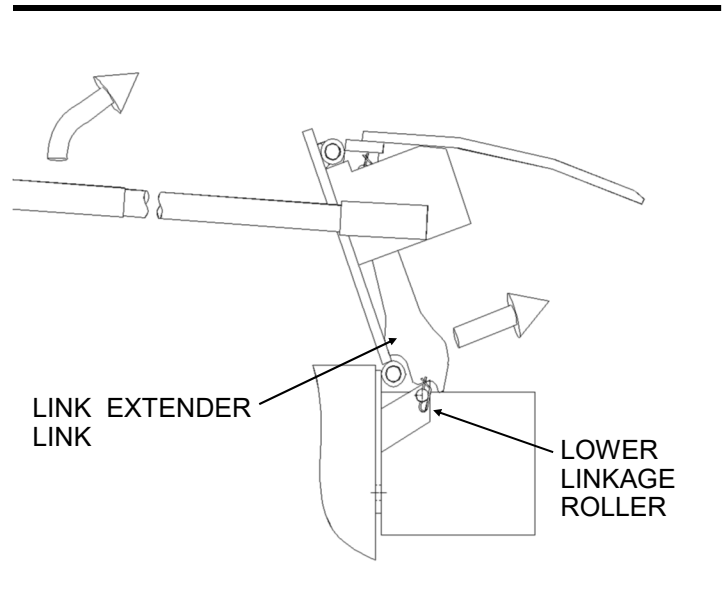
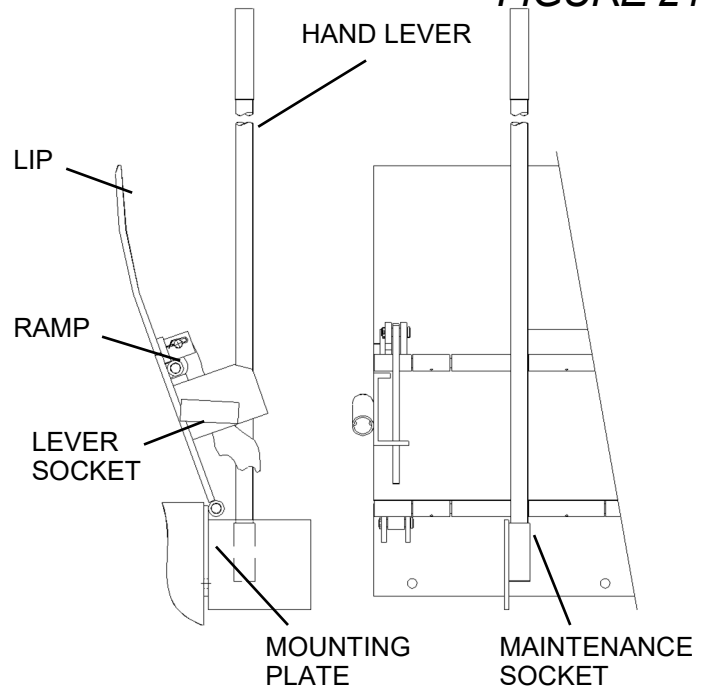

FIGURE 24



Inboard Handle Maintenance, CONTINUED

INSERT MAINTENANCE STRUT

1. (Hydraulic Only) While in the rest position (See *Figure 16*) remove the Rod Eye Bolt from the cylinder and slowly lower the cylinder and allow to hang loosely.

⚠ WARNING

Disconnect the hydraulic cylinder from the Edge-of-dock during maintenance or servicing. Failure to do so could result in death or serious injury.

2. Using the hand lever, position the dockleveler in the full back position. (See *Figure 18*).
3. While one person holds the hand lever down as shown in (*Figure 18*), another person standing on the drive surface, must position the lip to its full upright position as shown in (*Figure 25*).
4. With the ramp and lip in the full upright position, move the hand lever to the maintenance socket position as shown in (*Figure 25*). Place the round side of the handle into the maintenance socket and the tapered end of the handle facing up.

REMOVE MAINTENANCE STRUT

1. With the ramp and lip in the full back position, move the hand lever back to the lever socket as shown in (*Figure 18*).
2. While one person holds the hand lever down, as shown in (*Figure 18*), another person standing on the drive surface must position the lip to full back position as shown in (*Figure 18*).
3. Using the hand lever lower the dockleveler to the rest position as shown in (*Figure 22*). While lowering dockleveler to the rest position it is necessary to have another person use a pipe or similar device to hold the lip extender link from engaging on the extender pivot bushing as shown in (*Figure 23*), to prevent the lip from extending out away from the dock.

⚠ WARNING

Do not use hands or feet to hold lip extender link disengaged. Use of hands or feet could cause a pinch point resulting in serious injury or death.

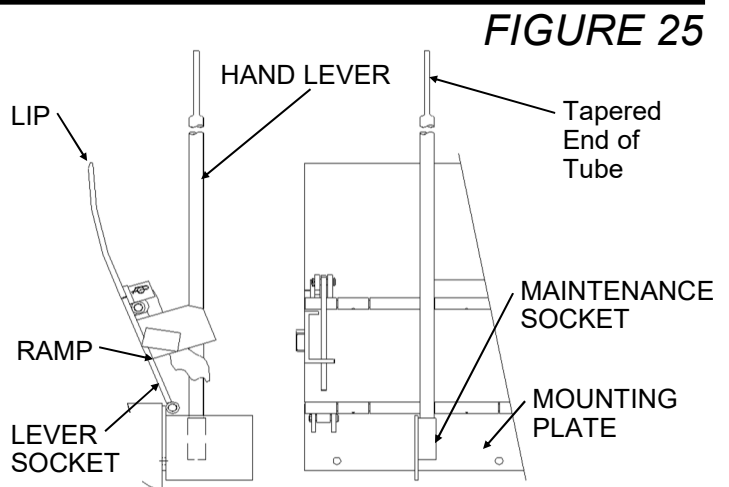

GENERAL MAINTENANCE

1. Every 90 days, with the dock leveler in the maintenance position, inspect all moving parts for wear or damage. Repair or replace, as necessary.
2. Inspect all welds, repair or replace as necessary.
3. If linkage parts must be replaced due to wear or damage, raise the leveler to its rear most position by means of the hand lever and **SECURE WITH THE MAINTENANCE STRUT.** (See *Figure 25*).
4. Lubricate all grease fittings every 90 days.
5. To increase spring tension, turn bolts in evenly. To decrease spring tension, turn bolts out evenly.
6. Every 90 days inspect dock bumpers. 4" of bumper protection is required. Worn, torn, loose or missing bumpers must be replaced.
7. Every 90 days check all labels. See Page 26 for part numbers and location. Replace as necessary.

MAINTENANCE, CONTINUED

8. Every 6 months verify that this is the latest and most up to date manual by visiting the manufacturer's website. (Download or order as needed)
9. Hydraulic units only. Seasonally change the hydraulic fluid for ambient temperatures change if appropriate or if there is any evidence of accumulating condensation creating water contamination.

WARNING

Do not over-adjust the extension springs. Over-adjusting extension springs may cause the dockleveler to bounce or float during use. Use of an over-adjusted dockleveler could result in death or serious injury.

OIL RECOMMENDATIONS

CAUTION

Do not use brake fluid or any other fluids not approved by the manufacturer. Use of fluids not approved by the manufacturer may attack the hydraulic systems seals and hoses.

FLUIDS

1. The first choice for fluid is Citco AW-46(200) hydraulic fluid. This is the fluid normally supplied by the factory and is suitable for a ambient temperature range of -10° to $+100^{\circ}$ Fahrenheit (-23°C to $+38^{\circ}\text{C}$).
2. Following is a recommended list of oils with a compatible ambient temperature range.
 - A. Amoco Oil Co.
Rycon Oil No. 32, 46
Amoco AW 32, 46
 - B. Cities Service Oil Co.
Citgo AW Hyd. Oil 32, 46
Citgo All Temp. Hyd. Oil
 - C. Chevron USA
Chevron EP Hyd. Oil 32, 46

- D. Fina Oil Co.
Fina AW 32, 46
Fina Automatic Transmission Fluid
Dexron II
- E. Gulf Oil Corporation
Gulf Harmony 32 AW, 46 AW
- F. Mobil Oil Corporation
DTE 15, 24, 25
Mobil Fluid #300 Transmission Fluid
- G. Sentinel Lubricants Corp.
Sentinel SH-10 Hydraulic Oil
- H. Shell Oil Co.
Tellus Hyd. Oil 32, 46
Tellus "T" Hyd. Oil 32, 46
- I. Texaco Inc.
Rando Oil Hd-32, 46
- J. Union 76
Xcel AW 46 (200)

3. For grease fittings use extreme pressure (EP) style grease

- A. Mobilux EP2
- B. Shell Gradus S2 V220
- C. Shell Retinax Grease EP2
- D. Valvoline Crimson EP grease



MAINTENANCE SCHEDULE

1st Month	Check hydraulic reservoir oil level.	Fill with hydraulic oil.	See pg. 25 for oil type
	Check the breather vent is in the correct location and is free and clear.	Install the vent cap in the correct location or replace.	See pg. 16 of this manual
	Check for damage to the hydraulic system or physical damage to the cylinder.	Replace or repair damaged parts or equipment.	Refer to parts lists and figures for parts listings.
	Inspect EOD for damage, broken welds, or worn parts	Replace or repair as needed	Refer to parts lists and figures for parts listings.
	Inspect paint	Touch up as needed	
	Grease all tubes on EOD	Apply grease until grease begins to come out at tube ends	See pg. 25 for type of grease
Every Three Months	At the cylinder: Check for bent or damaged rods.	Replace cylinder	Refer to parts lists and figures for parts listings.
	Inspect EOD for damage, broken welds, or worn parts	Replace or repair as needed	Refer to parts lists and figures for parts listings.
	Inspect Dock Bumpers	Inspect rubber for wear 4" of projection is required	Refer to parts lists and figures for parts listings.
	Check hydraulic reservoir oil level.	Fill with hydraulic oil.	See pg. 25 for oil type
	Check the breather vent is open for operation.	Replace or install the breather cap in the correct location	See pg. 16 of this manual
	Inspect Warning Labels and Placards	Replace as needed	See pg. 31 of this manual
	Check for foreign objects jammed in the hydraulics or under the EOD.	Remove any foreign objects.	
	Grease all tubes on EOD	Apply grease until grease begins to come out at tube ends	See pg. 25 for type of grease
Every Six Months	Complete Three Month Maintenance	See this Chart	
	Check for damage to the hydraulic system or physical damage to the cylinder.	Replace or repair damaged parts or equipment.	Refer to parts lists and figures for parts listings.
	Inspect paint	Touch up as needed	
	Inspect handle	Replace if worn, damaged or missing	Refer to parts lists and figures for parts listings.
Every 12 Months	Complete Six Month Maintenance	See this Chart	
	Replace Hydraulic Oil	Change out hydraulic oil	See pg. 25 for oil type
	Check Spring Force	Adjust as needed or replace if damaged or worn	See Maintenance Section

TROUBLE SHOOTING

Issue	Cause	Repair
<i>The EOD is not actuating properly, the linkage does not lock onto the roller when EOD is pulled back.</i>	Verify EOD linkage is able to rotate onto the roller when the EOD is in the full back position. The linkage should move freely and have a slight gap between the roller and the bottom of the linkage.	Grind the area of the linkage that rests on the roller slightly to increase the amount of clearance. Grind straight and level. (See Figure #26)
	Verify the welds on the tubes at the mounting plate near the edge of the dock are not keeping the EOD from going fully back. The hand lever should be parallel with the ground when fully back.	Grind any welds to clear the dock when the EOD is in the back position.
<i>The EOD bounces and raises when driven over and resting on a truck.</i>	Verify the springs are not over tightened. If the springs are over tightened this could cause the EOD to fold back into the rest position when being used.	Loosen the springs (See General Installation pg #14)
<i>The EOD will not pull back or the lip and ramp do not hinge freely</i>	Verify the tubes are properly greased. See maintenance section of this manual.	Grease tubes if needed.
Hydraulic EOD		
<i>The EOD will not actuate properly, the linkage does not lock onto the roller when the EOD is raised fully.</i>	Verify EOD linkage is able to rotate onto the roller when the EOD is in the full back position. The linkage should move freely and have a slight gap between the roller and the bottom of the linkage.	Grind the area of the linkage that rests on the roller slightly to increase the amount of clearance. Grind straight and level. (See Figure #26)
	Verify the welds on the tubes at the mounting plate near the edge of the dock are not keeping the EOD from going fully back. The hand lever should be parallel with the ground when fully back.	Grind any welds to clear the dock when the EOD is in the back position.
	The Hydraulic cylinder is not raising the EOD back fully. Check this by disconnecting the cylinder from the EOD and manually activating the EOD. If the EOD works manually than the cylinder is not lifting the EOD back far enough to engage the linkage.	Adjust the cylinder eyelet out so the hydraulic cylinder assembly is longer. See pg 16 of this manual. Verify the Upper Mounting Bracket is welded in the correct location and orientation. See pg 16 of this manual. Verify there is sufficient hydraulic fluid in the reservoir. The reservoir should be 1/2 or more full.
<i>EOD will not raise or lower.</i>	The motor is not running when either "UP" or "DOWN" is pressed	Check to see if the motor is getting voltage and verify that it is the correct voltage when either button is depressed.
		Verify the Overload is set to Aut on reset and that it is not "tripped"
		On single phase units verify there is correct voltage (120VAC or 230VAC) between A118 and 95 on the overload. On 3-phase units verify there is 24volts between A124 and 95 on the overload.
	The motor is running when either "UP or "DOWN is pressed	For Single Phase check voltage between A106 and A109 on the terminal block and A107 and A110 for correct voltage (120VAC or 230VAC) when the buttons are pressed For 3-Phase check voltage between A106 and A117 on the terminal blocks and A107 and A118 for 24volts when the buttons are pressed.
		Verify the Solenoids are working properly, they can be removed by loosening and removin the nut on the top of the valve stem. Slide the solenoids off the valve and check with a metal screw driver inside the solenoid. It should magnetize once the corresponding button is pressed. The Valve may be damaged.

FIGURE #26

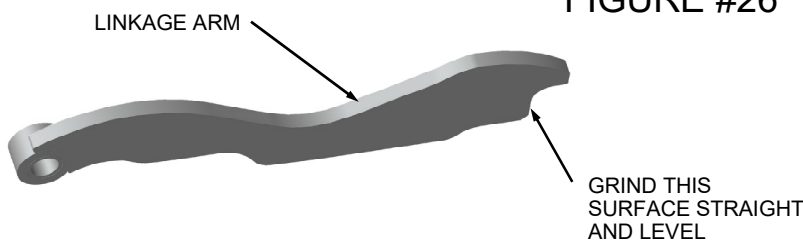

STANDARD PARTS LIST

tem	Qty.	Part Description	Part #	
			20K Capacity	30K Capacity
1	1	Vinyl Handle Grip	024-023	024-023
2	1	Handle Lever w/ vinyl handle grip	095-352	095-352
3	1	Extender Linkage	SEL-02-00033	SEL-02-00033
4	1	5/8"-2-1/2" Clevis Pin	SEL-05-00001	SEL-05-00001
5	3	5/8"-2" Clevis Pin	SEL-05-00004	SEL-05-00004
6	1	Spring Support Shaft	SEL-02-00008	SEL-02-00008
7	2	3/16" Spring Roll Pin	002-065	002-065
8	1	Upper Spring Linkage Bar	7224B01	7224B01
9	1	Lower Spring Linkage Bar	7225B01	7225B01
10	2	Extension Spring	5539B01 (2)	5539B01 & 5539B02
11	2	Nut, Hx, 3/8"-16, Pltd	024-028	024-028
12	2	Scr, Hx, Gr2, 3/8"-16 x 5-1/2"	002-143	002-143
13	2	Wshr, Fl, Fender, 2" O.D.	002-144	002-144
14	1	Lower Extender Linkage Roller w/bushings	SEL-02-00012	SEL-02-00012
15	2	Linkage Pin Lug (Welded)	SEL-02-00504	SEL-02-00504
16	1	Handle Socket Sub-weldment (Welded)	SEL-01-00010	SEL-01-00029
17	3	Nylon Sleeve Bushing	SEL-04-00001	SEL-04-00001
18	2	Lower Pin Bracket (Welded)	SEL-02-00009	SEL-02-00009
19	6	Spring Lug (Welded)	SEL-02-00035	SEL-02-00035
20	4	5/8" .072 Pltd. Rue Ring	002-147	002-147
21	12	Grease Fitting	002-062	002-062

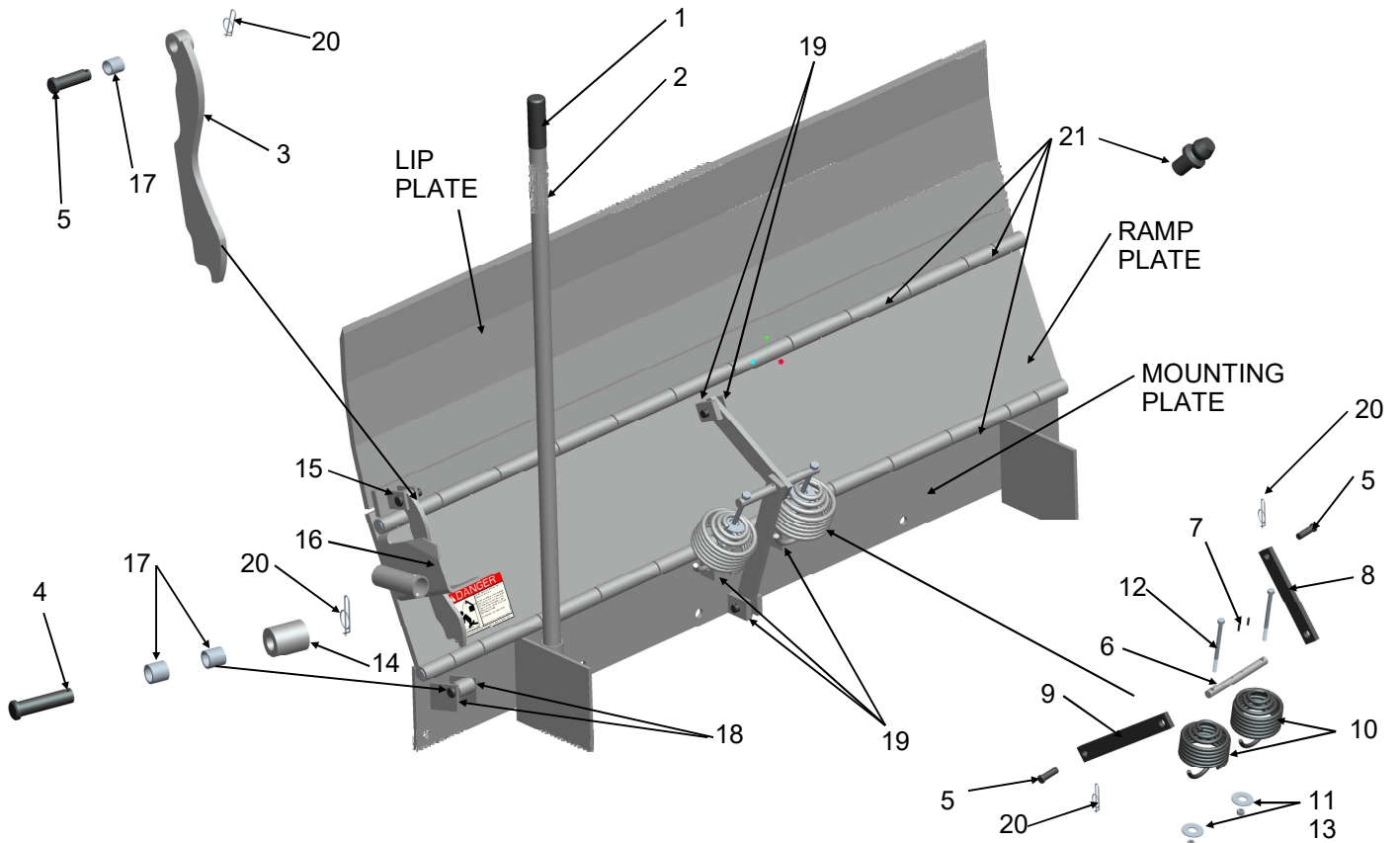

INBOARD HANDLE PARTS LIST

Item	Qty.	Part Description	Part #	
			20K Capacity	30K Capacity
22	1	Handle End Cap	SEL-04-00016	SEL-04-00016
23	1	Inboard Handle Lever w/ Removable Cap	SEL-02-00060	SEL-02-00060
24	1	Inboard Socket Sub-weldment	SEL-01-00009	SEL-01-00006

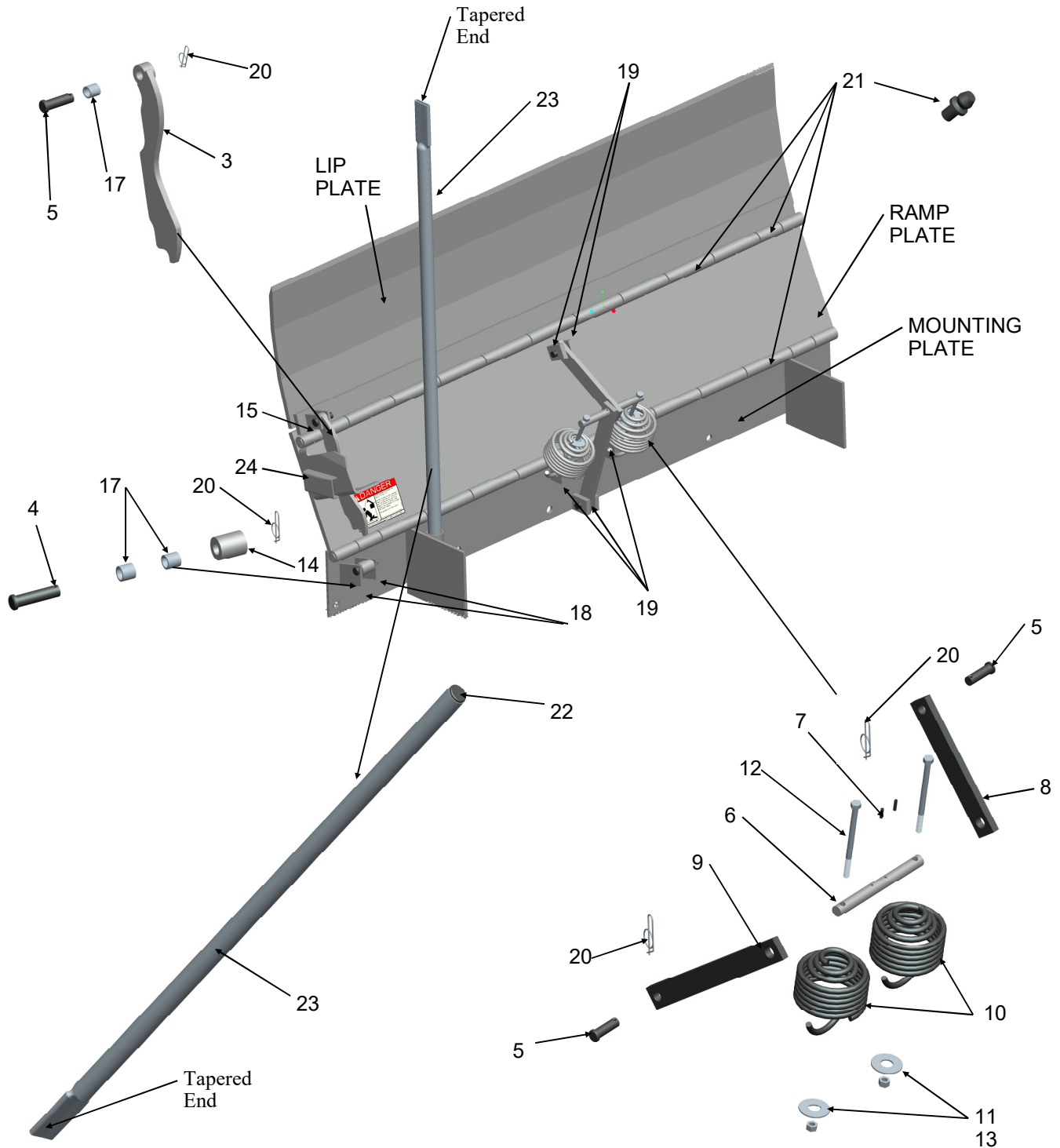

STANDARD BUMPER PARTS LIST

Item	Qty.	Description	Part #
	2	Complete bumper block assembly, 2-Hole	SEL-01-00094
25	2	10"x13"x4" Molded Rubber Bumper (Standard)	SEL-04-00011
26	4	Scr, Hx, Gr2, 3/4"-10	002-163
27	4	Wshr, Fl, Standard, 3/4"	002-156
28	4	Nut, Center Lock, 3/4"-10	002-159
29	2	10x13x12, Steel Block Weldment (2-Hole)	SEL-01-00082

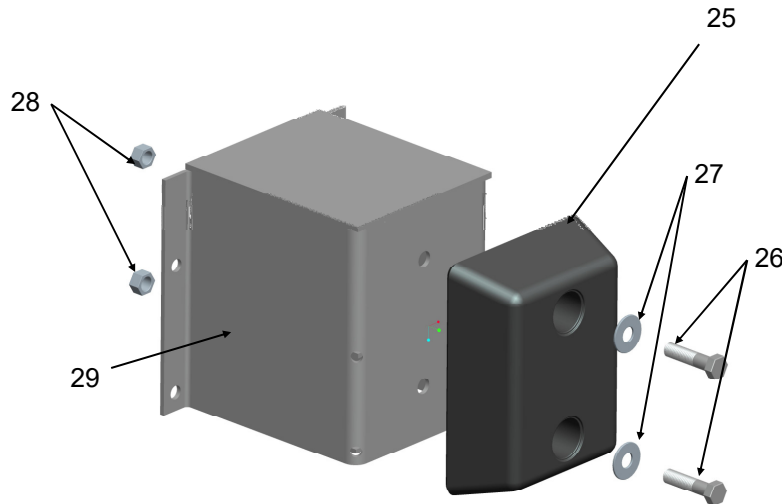

OPTIONAL BUMPER PARTS LIST

Item	Qty.	Description	Part #
	2	Complete bumper block assembly, 4-Hole	5552CA
30	2	12"x13"x4" Molded Rubber Bumper (Standard)	SEL-04-00015
31	8	Scr, Hx, Gr2, 1/2"-13 x 3.00"	002-071
32	8	Wshr, Fl, Std, 1/2"	009-004
33	8	Nut, Hx, 1/2"-13	002-145
34	8	Wshr, Lock, 1/2"	002-146
35	2	12x13x12, Steel Block Weldment (4-Hole)	5551CA

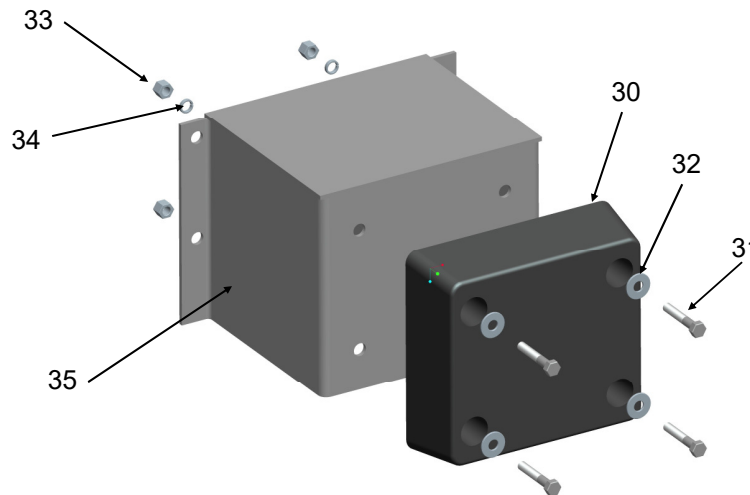

LABEL PARTS LIST



1 SEL-12-00054-B EOD Danger Label (Place on underside of Ramp Plate Typ. of one)

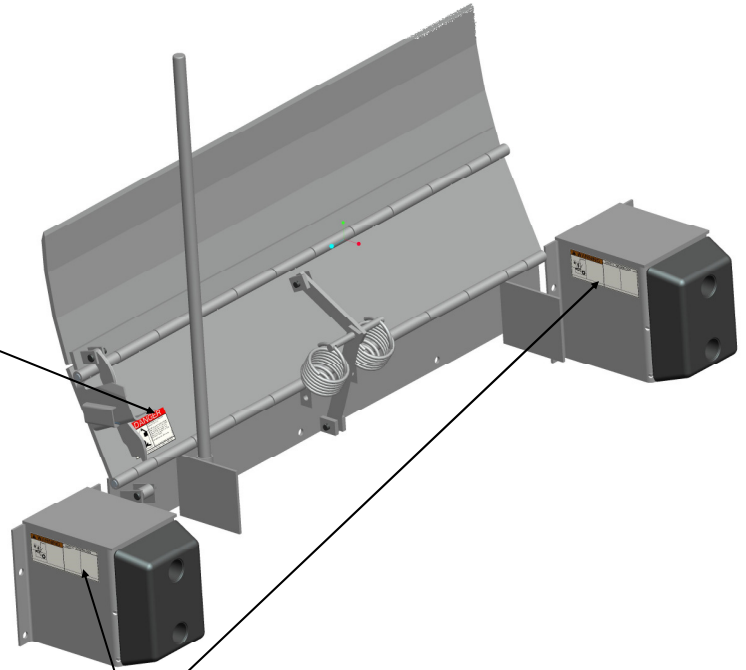

2 SEL-12-00053-C EOD Danger Label (Place on exterior side of left bumper & interior side of right bumper Typ. of two)

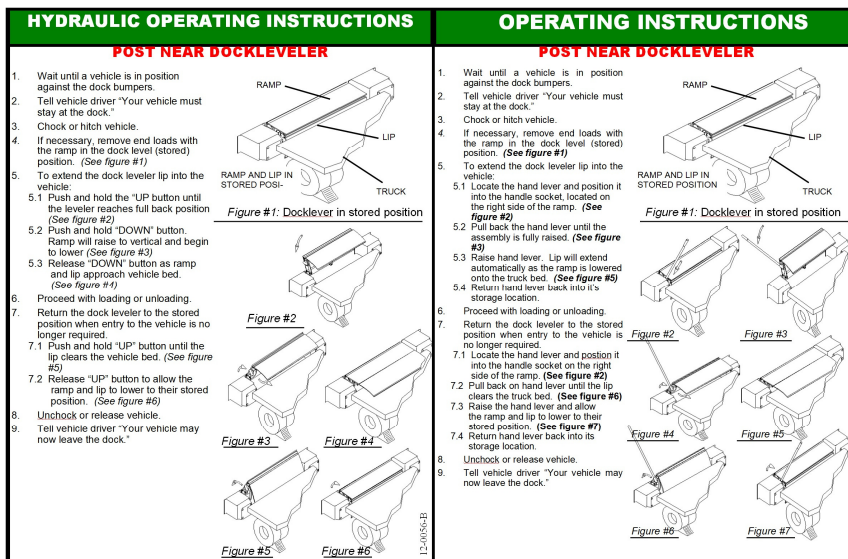

4 SEL-12-00056-B Mechanical EOD Danger Placard (Post near EOD Typ. of one)

LABEL PARTS LIST

EOD SEL Hydraulic Power Pack Labels

5 SEL-12-00053-C EOD Danger Label (Place on exterior side of left bumper & interior side of right bumper Typ. of two)

6 SEL-12-00101 EOD Warning Label (Place on hydraulic electric box lined up with holes for pushbuttons)

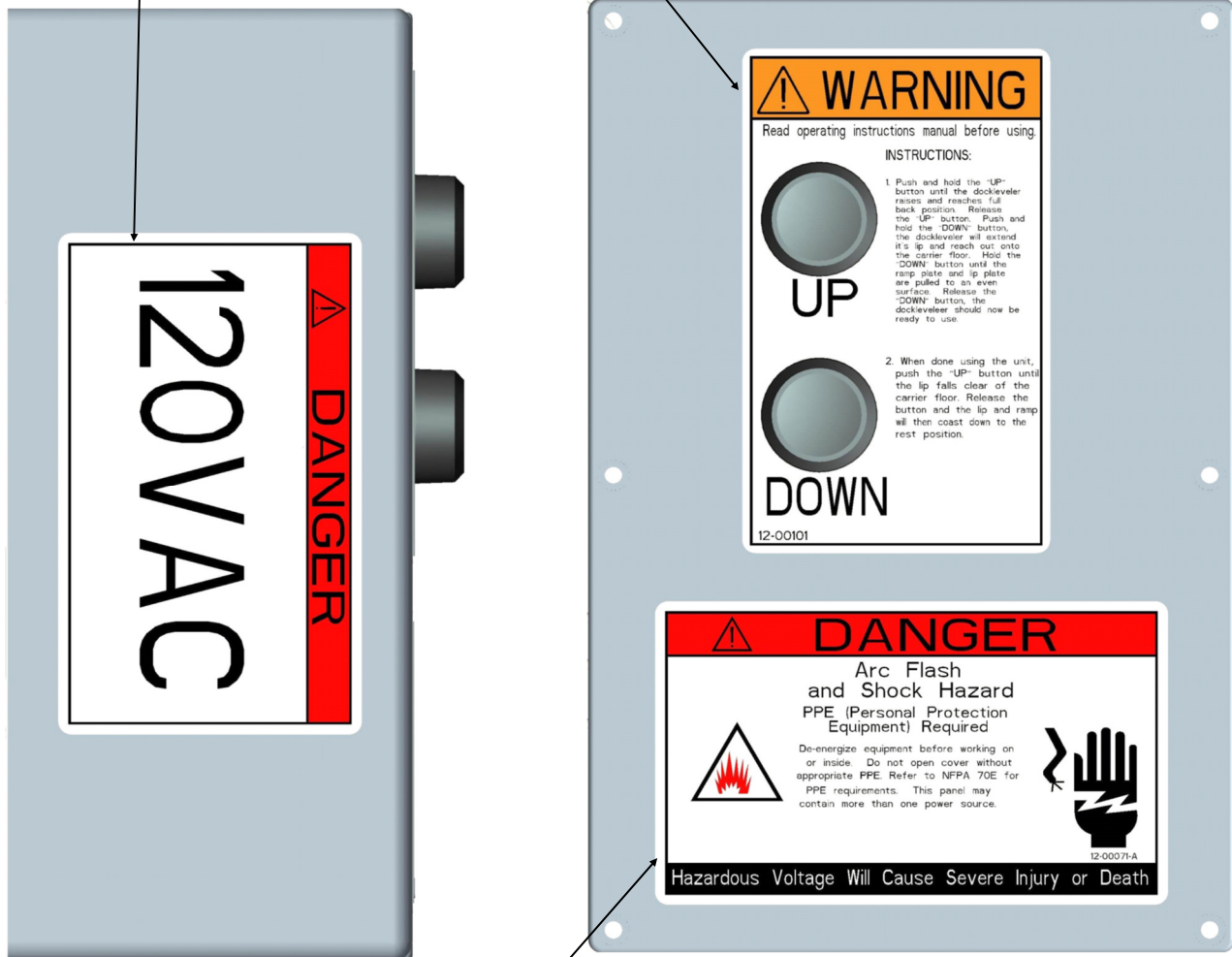

7 SEL-12-00071 EOD Danger Label (Place on hydraulic electrical box centered on box front)

HYDRAULIC SCHEMATICS

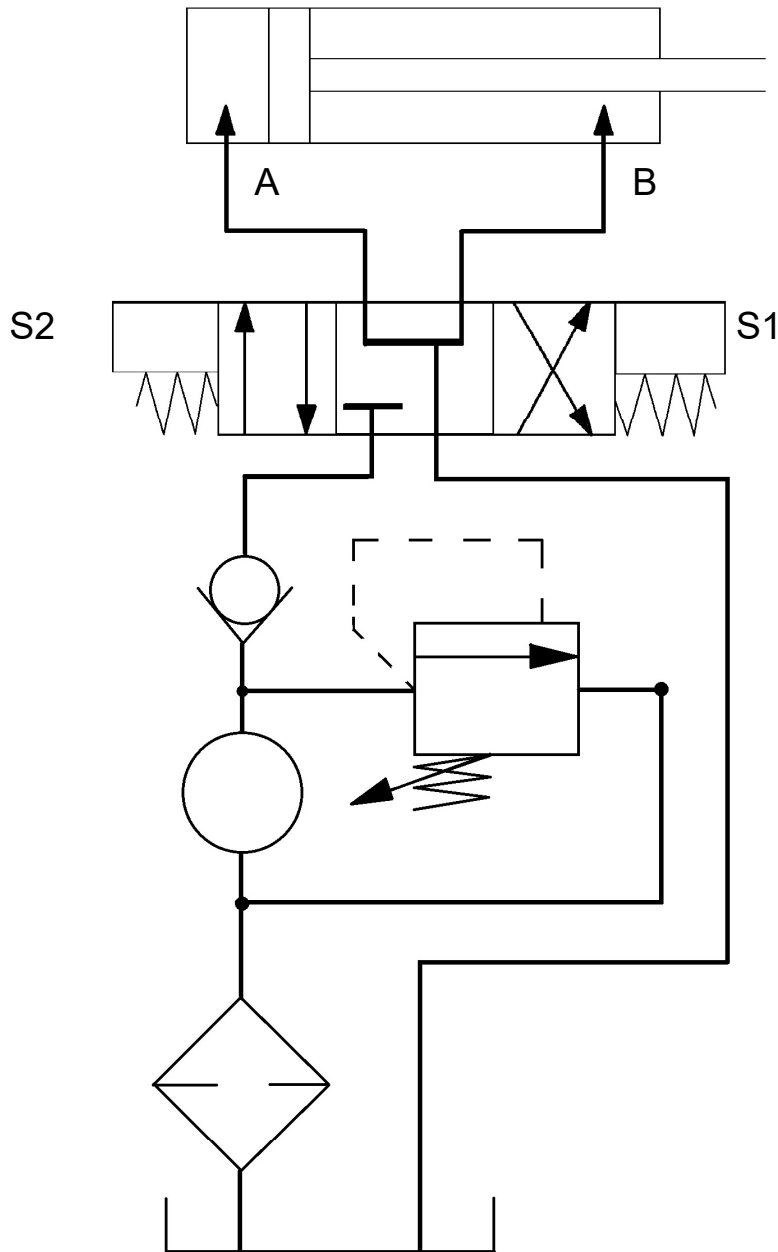

SINGLE PHASE 120VAC ELECTRICAL SCHEMATIC

⚠ WARNING

Before doing any electrical work, make certain that all power sources are disconnected and properly tagged or locked out per OSHA requirements. All electrical work must be done by a qualified technician and must meet all applicable codes. Failure to do so could result in electrical shock, serious injury or death.

115V, SINGLE PHASE, 50/60 Hz

MOTOR WIRING DIAGRAM

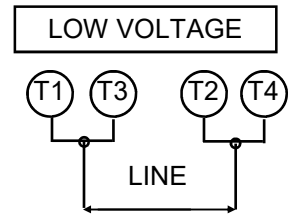

WIRE CONNECTIONS (IN FIELD):

20amp Disconnect to Terminal Block Connections
 Disconnect Hot to A105 (Black 12ga.)
 Disconnect Common to A103 (White 12ga.)
 Disconnect Ground to A113 (Green 12ga.)

Terminal Block to Motor Box
 A111 to T1 & T3 on Motor (Black 12ga.)
 A112 to T2 & T4 on Motor (White 12ga.)
 A114 to Ground on Motor (Green 12ga.)

A109 to Black Wire on Solenoid 1 (Black 18ga.)
 A110 to Black Wire on Solenoid 2 (Black 18ga.)

A106 to White Wire on Solenoid 1 (White 18ga.)
 A107 to White Wire on Solenoid 2 (White 18ga.)
 (Both White Wires from solenoids can be tied together only needing one connection to A106 or A107)

A101 to Green Wire on Solenoid 1 (Green 18ga.)
 A102 to Green Wire on Solenoid 2 (Green 18ga.)
 (Both Ground wires from solenoids can be tied together only needing one connection to A101 or A102)

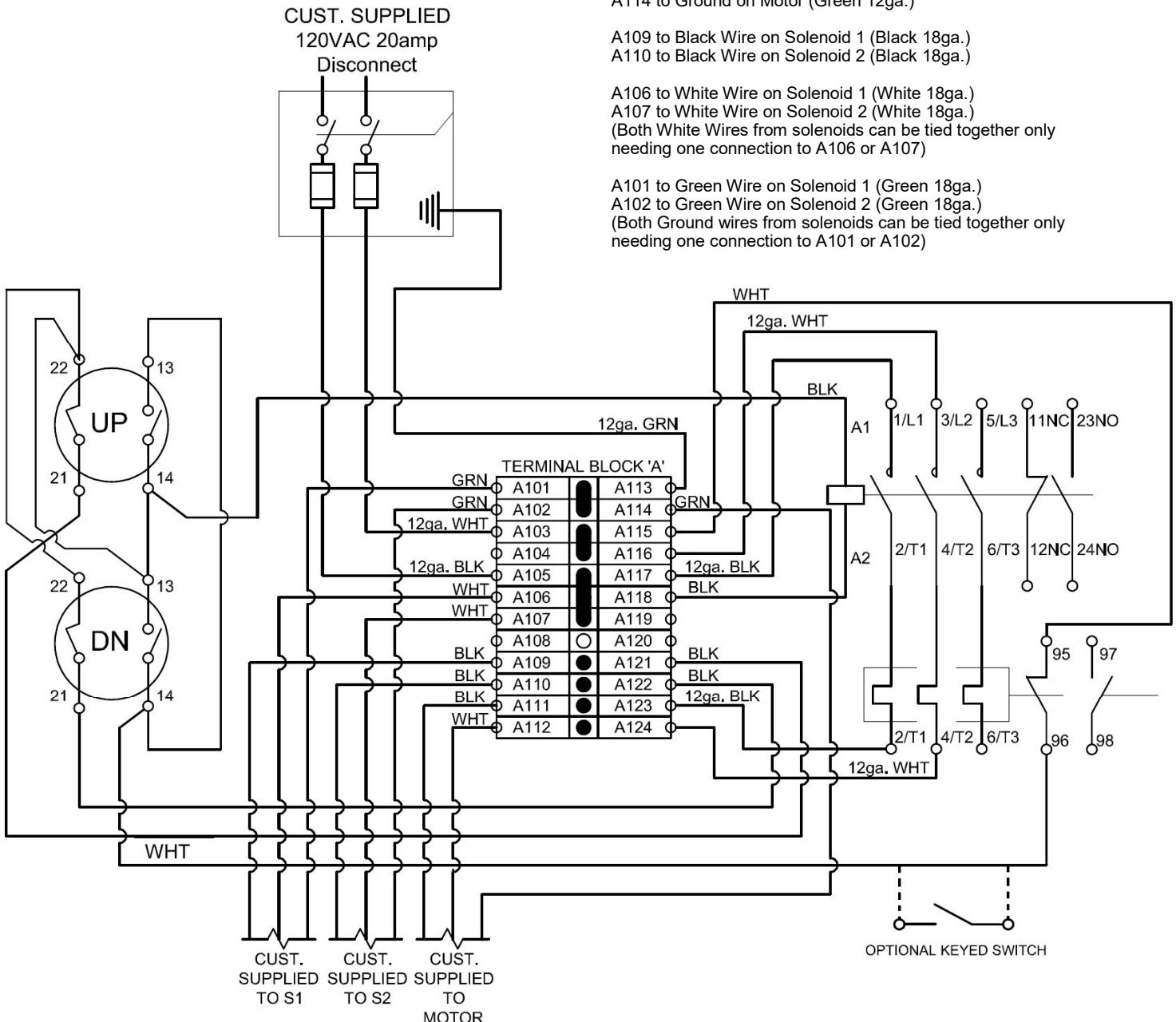

SINGLE PHASE 120V ENCLOSURE ASSEMBLY

Item	Qty.	Description	Part #
	1	120V, Single Phase Control Box Assembly	06-00129
1	1	Contactora, 18amp, 120VAC Coil	06-00121
2	1	Overload, 12-18amps	06-00127
3	2	Pushbutton	063-026
4	1	6.25"x9.50"x5.75", Nema 12 Enclosure	063-027
5	1	12 Pole Terminal Block	06-00006
6	4	Line-toLine Terminal Block Jumpers	06-00008
7	1	6"x9" Enclosure Backplate (Fab)	SEL-02-01006
8	1	Single phase Terminal Block Label	12-00150
9	*	Optional Keyed Lockout	06-00071

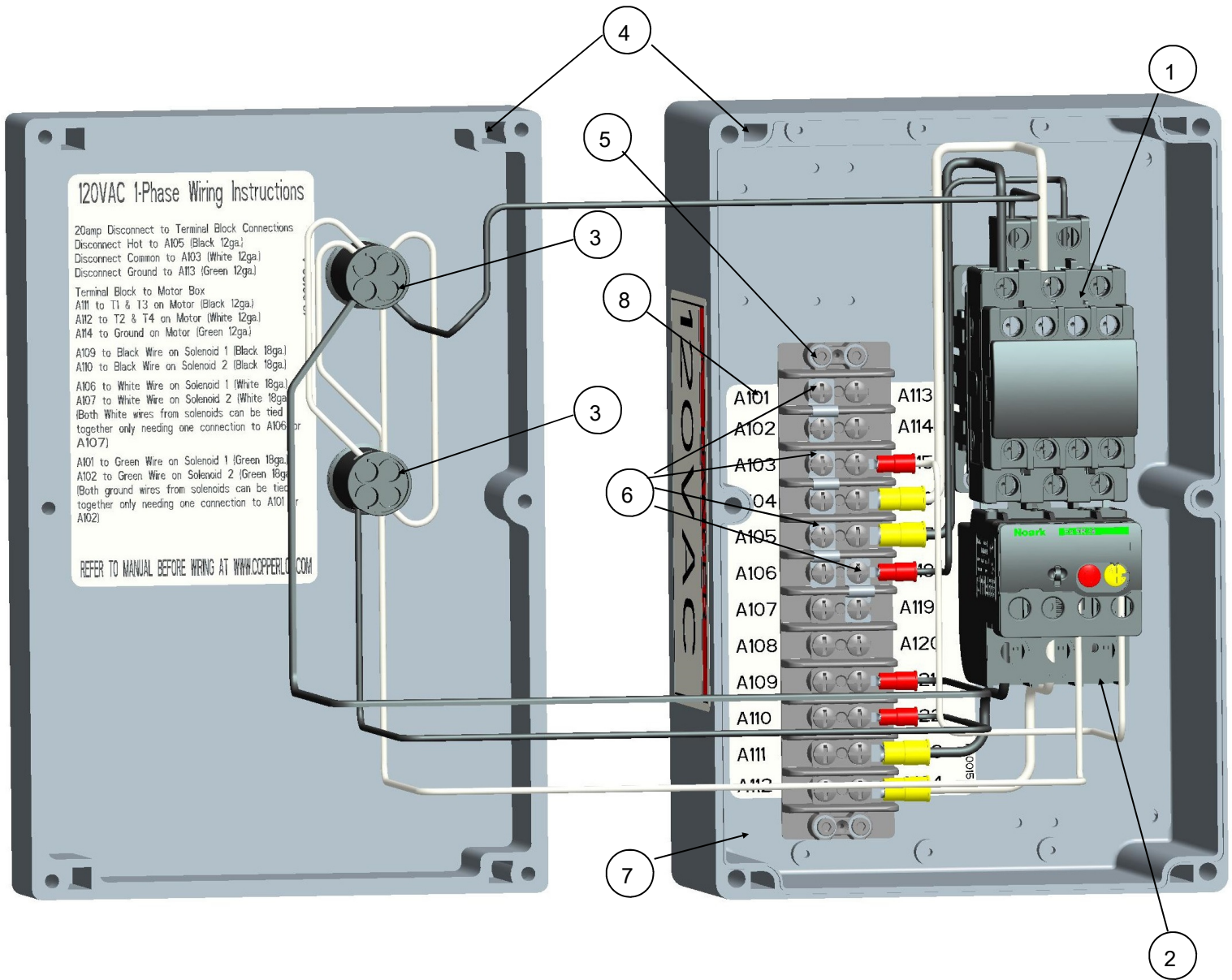

SINGLE PHASE 230V ELECTRICAL SCHEMATIC

WARNING

Before doing any electrical work, make certain that all power sources are disconnected and properly tagged or locked out per OSHA regulations. All electrical work must be done by a qualified technician and must meet all applicable codes. Failure to do so could result in electrical shock, serious injury or death.

MOTOR WIRING DIAGRAM

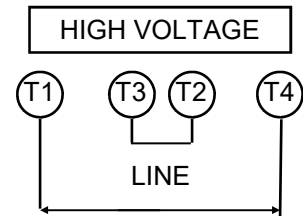

230V, SINGLE PHASE, 50/60 Hz

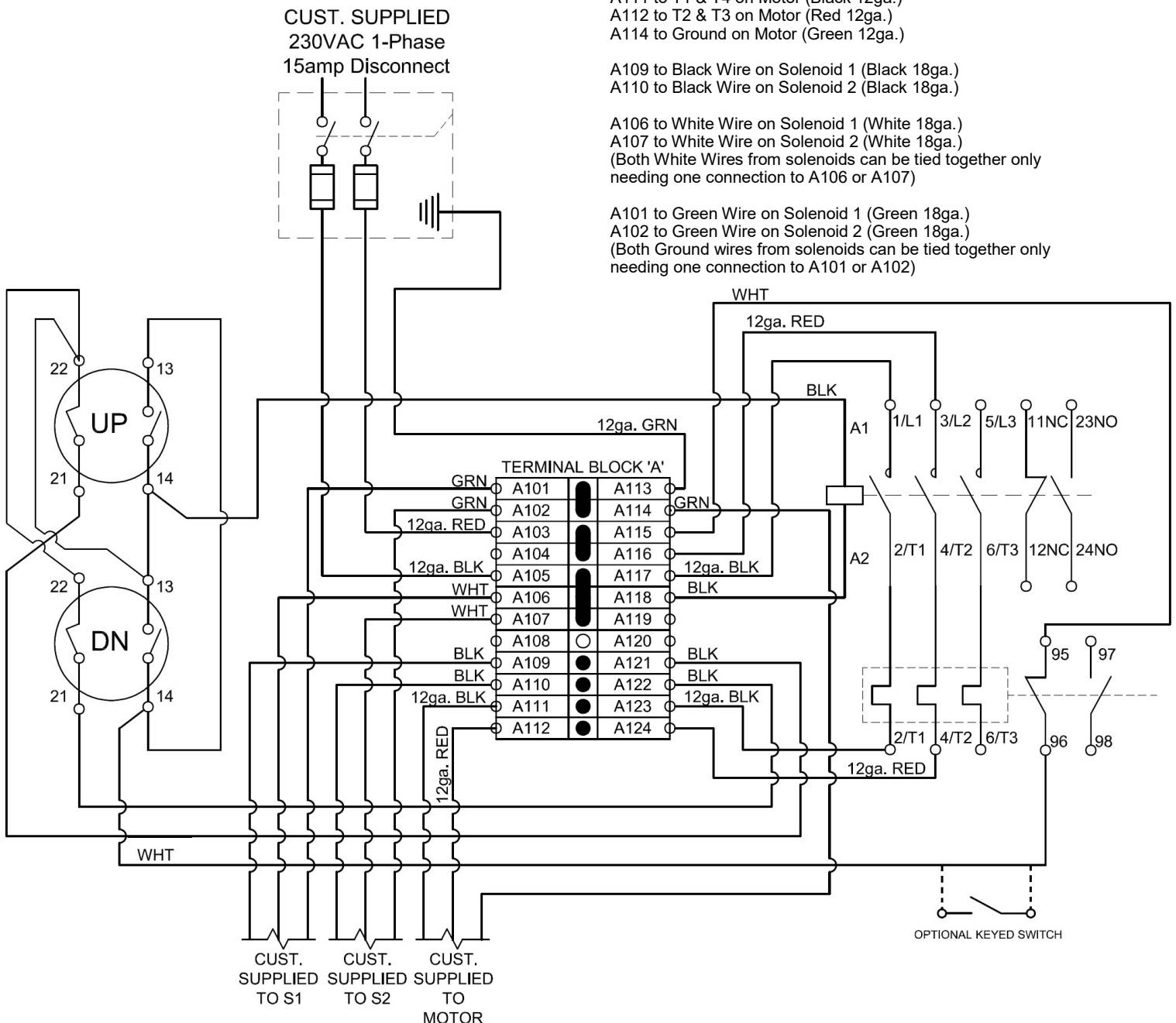

SINGLE PHASE 230V ENCLOSURE ASSEMBLY

Item	Qty.	Description	Part #
	1	230V, Single Phase Control Box Assembly	06-00130
1	1	Contactor, 18amp, 230VAC Coil	06-00122
2	1	Overload, 5.5-8amps	06-00126
3	2	Pushbutton	063-026
4	1	6.25"x9.50"x5.75", Nema 12 Enclosure	063-027
5	1	12 Pole Terminal Block	06-00006
6	4	Line-to-Line Terminal Block Jumpers	06-00008
7	1	6"x9" Enclosure Backplate (Fab)	SEL-02-01006
8	1	Single phase Terminal Block Label	12-00150
9	*	Optional Keyed Lockout	06-00071
10	1	230VAC 1-Phase Wiring Label	12-00167

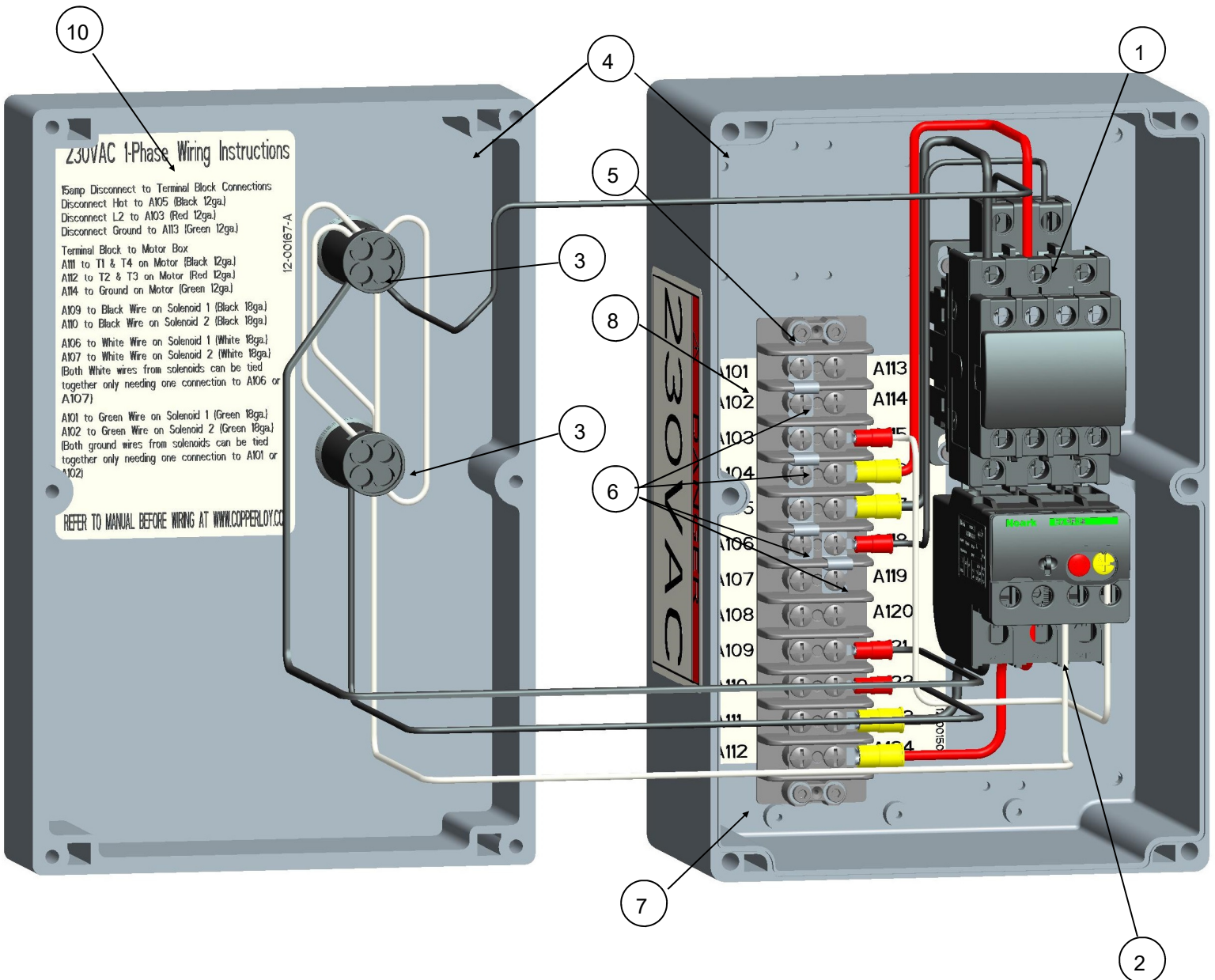

PARTS 1-PHASE INSTALLED ASSEMBLY

Item #	Qty.	Description	1-Phase Voltage	
			120VAC	230VAC
1	1	Hydraulic Power Pack, Assembly	7649DA	7649DA
2	4	5/16"-18x1.00" HH Scr Grd 5	002-054	002-054
3	4	5/16" Flat Washer	046-004	046-004
4	4	5/16"-18 Rev. Lock Nut	024-010	024-010
5	2	5/8"-11 Rev. Lock Nut	002-047	002-047
6	1	5/8"-11x2-3/4" HH Scr Grd. 5	002-045	002-045
7	1	Lower Hydraulic Cylinder Mtg. Bracket	7648DA	7648DA
8	3	Elbow, 90°, #6 SAE 37° to #6 O-Ring	063-002	063-002
9	1	Hydraulic Cylinder, 1-1/2" Dia. X 12" Stroke	063-001	063-001
10	1	90° #6 SAE O-Ring to #6 SAE 37°, Long	063-022	063-022
11	1	Upper Hydraulic Cylinder Mtg. Bracket	7438B01	7438B01
12	1	Push Button Control Box	06-00129	06-00130
13	1	5/8"-11x2.00" HH Scr Grd. 5	002-058	002-058
14	1	5/8"-18 Fine Thread Hex Nut Grd 8	063-005	063-005
15	1	Female Plain Ball Rod End 5/8"-18	063-004	063-004
16	2	1/4" Hydraulic Hose Assembly EOD	7654BA	7654BA
17	2	1-Phase Solenoid	063-006	063-006
18	1	Double Hydraulic Valve	063-008	063-008
19	2	DIN Plug w/3'-0" Pigtail	203-120	203-120

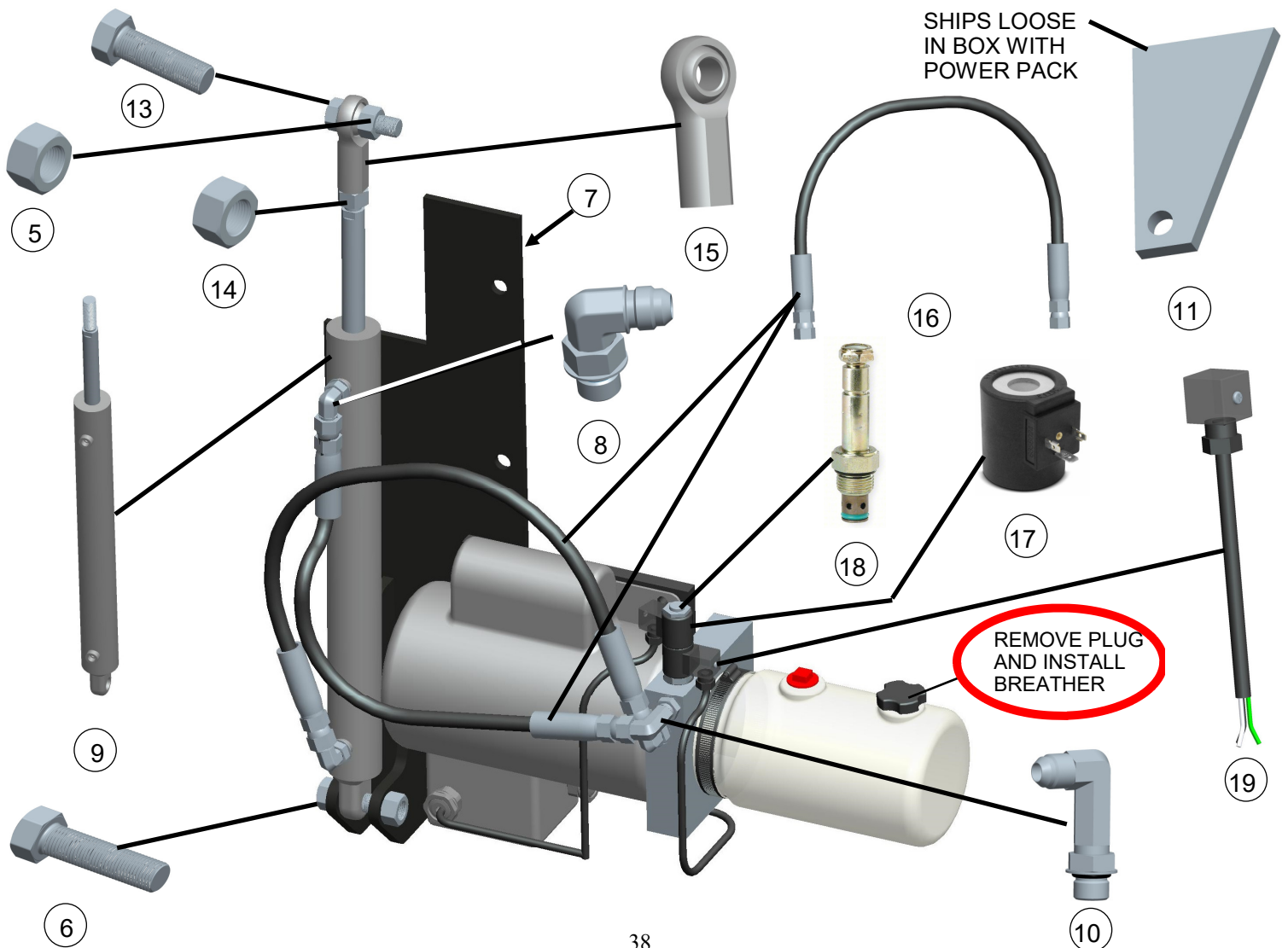

3-PHASE ELECTRICAL SCHEMATIC

230/460V, 3-PHASE, 50/60 Hz, (WALL MOUNT PUSH BUTTON)

WIRE CONNECTIONS (IN FIELD):

- Disconnect to Terminal Block Connections
- Disconnect L1 (12ga. Black) to A105
- Disconnect L2 (12ga. Red) to A103
- Disconnect L3 (12ga. Blue) to A102
- Disconnect Ground (12ga. Green) To A120

- Terminal Block to Motor Box
- A112 (12ga. Black) to L1 Motor Connection
 - A111 (12ga. Red) to L2 Motor Connection
 - A110 (12ga. Blue) to L3 Motor Connection
 - A121 (12ga. Green) to Motor Ground Connection

- A106 to Black Wire on Solenoid 1 (Black 18ga.)
- A107 to Black Wire on Solenoid 2 (Black 18ga.)

- A110 to White Wire on Solenoid 1 (White 18ga.)
- A111 to White Wire on Solenoid 2 (White 18ga.)
- (Both White Wires from solenoids can be tied together only needing one connection to A110 or A111)

- A108 to Green Wire on Solenoid 1 (Green 18ga.)
- A109 to Green Wire on Solenoid 2 (Green 18ga.)
- (Both ground wires from solenoids can be tied together only needing one connection to A108 or A109)

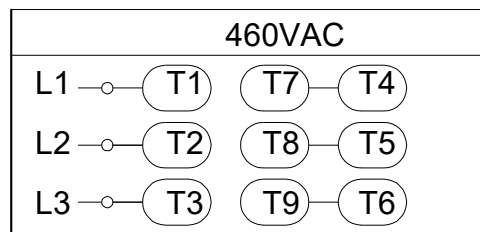
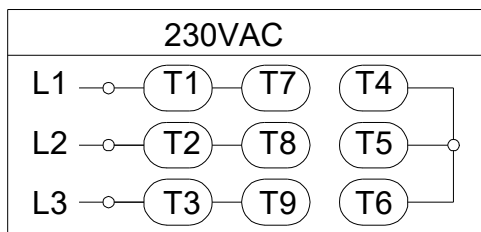
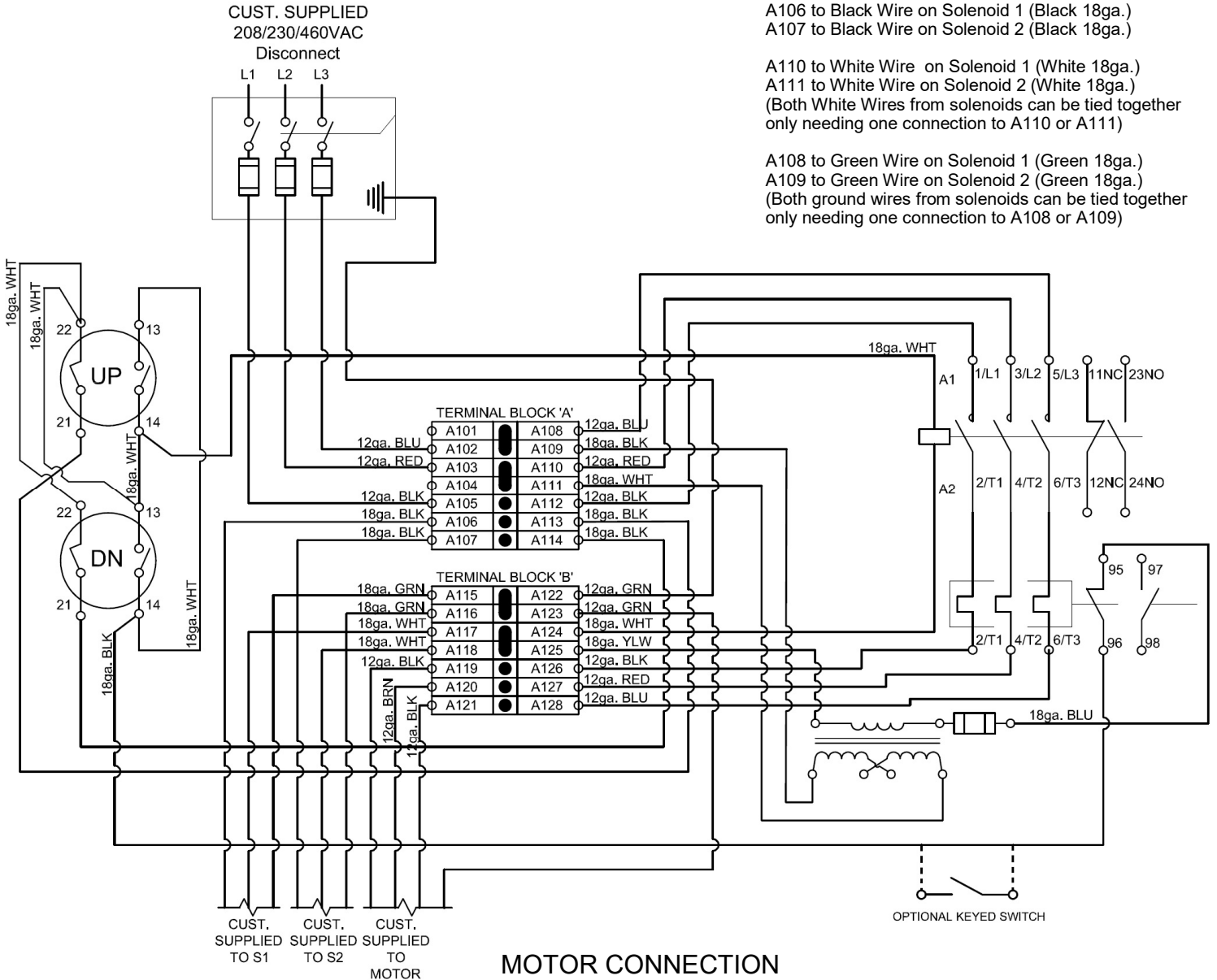

PARTS- 3-PHASE ENCLOSURE ASSEMBLY

Item	Qty.	Description	Part #
	1	230VAC/460VAC, 3-Phase Control Box Assembly	06-00132/06-00133
1	1	Contactor, 17amp, 24VAC Coil	06-00120
2	1	Overload, (230VAC 2.5-4.0A/460VAC 1.6-2.5A)	06-00125/06-00124
3	2	Pushbutton	063-026
4	1	6.25"x9.50"x5.75", Nema 12 Enclosure	063-027
5	2	7 Pole Terminal Block	06-00007
6	4	Line-toLine Terminal Block Jumpers	06-00008
7	1	24V Transformer	10262
8	1	6"x9" Enclosure Backplate (Fab)	SEL-02-01006
9	1	Three phase Terminal Block Label	12-00150
10	1	230/460VAC Wiring Instruction Label	12-00168/06-00169
11	*	Optional Keyed Lockout	06-00071

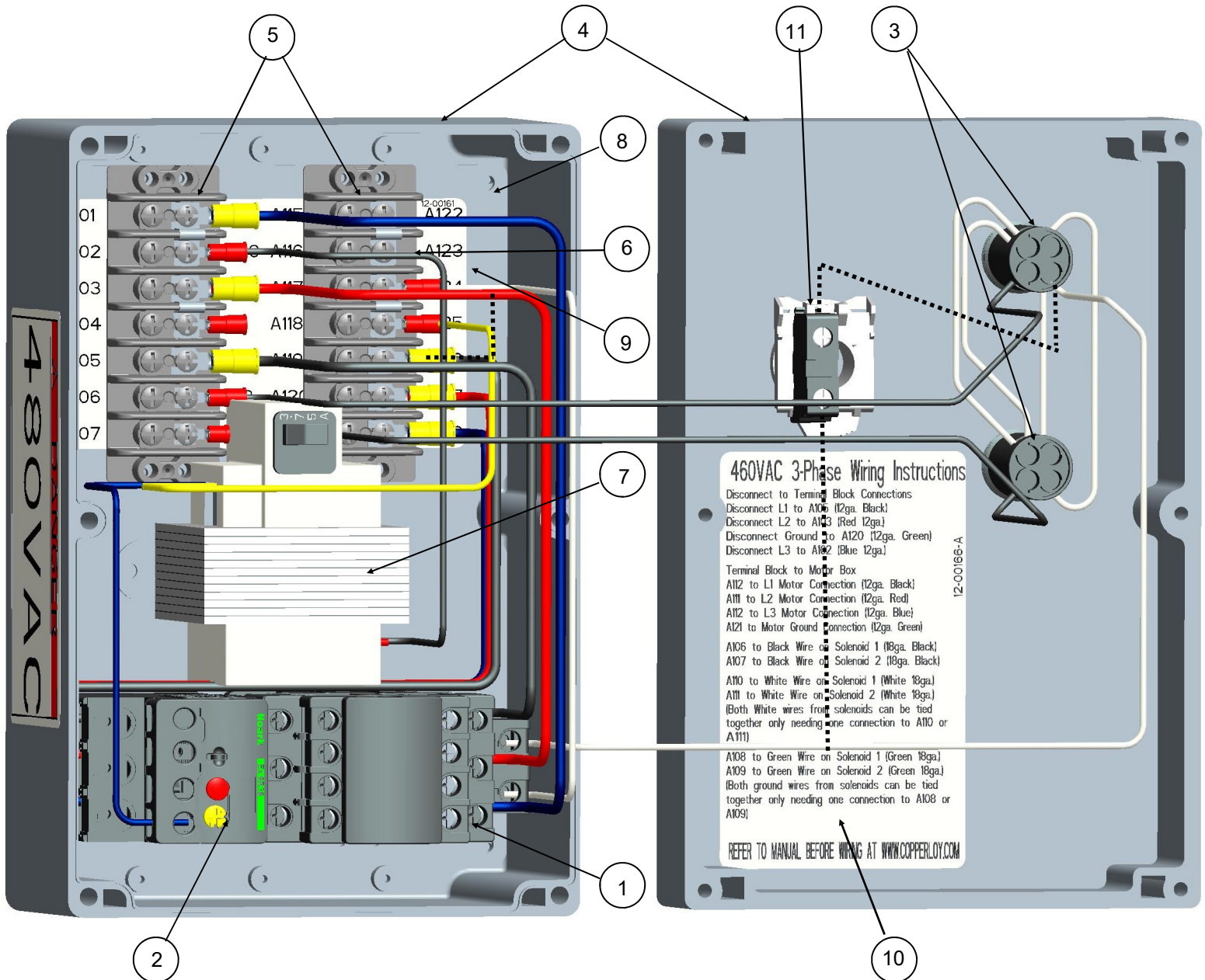

PARTS 3-PHASE INSTALLED ASSEMBLY

Item #	Qty.	Description	3-Phase Voltage	
			208/230VAC	460VAC
1	1	Hydraulic Power Pack, Assembly	7681DA	7681DA
2	4	5/16"-18x1.00" HH Scr Grd 5	002-054	002-054
3	4	5/16" Flat Washer	046-004	046-004
4	4	5/16"-18 Rev. Lock Nut	024-010	024-010
5	2	5/8"-11 Rev. Lock Nut	002-047	002-047
6	1	5/8"-11x2-3/4" HH Scr Grd. 5	002-045	002-045
7	1	Lower Hydraulic Cylinder Mtg. Bracket	7648DA	7648DA
8	3	Elbow, 90°, #6 SAE 37° to #6 O-Ring	063-002	063-002
9	1	Hydraulic Cylinder, 1-1/2" Dia. X 12" Stroke	063-001	063-001
10	1	90° #6 SAE O-Ring to #6 SAE 37°, Long	063-022	063-022
11	1	Upper Hydraulic Cylinder Mtg. Bracket	7438B01	7438B01
12	1	Push Button Control Box	06-00132	06-00133
13	1	5/8"-11x2.00" HH Scr Grd. 5	002-058	002-058
14	1	5/8"-18 Fine Thread Hex Nut Grd 8	063-005	063-005
15	1	Female Plain Ball Rod End 5/8"-18	063-004	063-004
16	2	1/4" Hydraulic Hose Assembly EOD	7654BA	7654BA
17	2	3-Phase Solenoid	063-007	063-007
18	1	Double Hydraulic Valve	063-008	063-008
19	2	DIN Plug w/3'-0" Pigtail	203-120	203-120

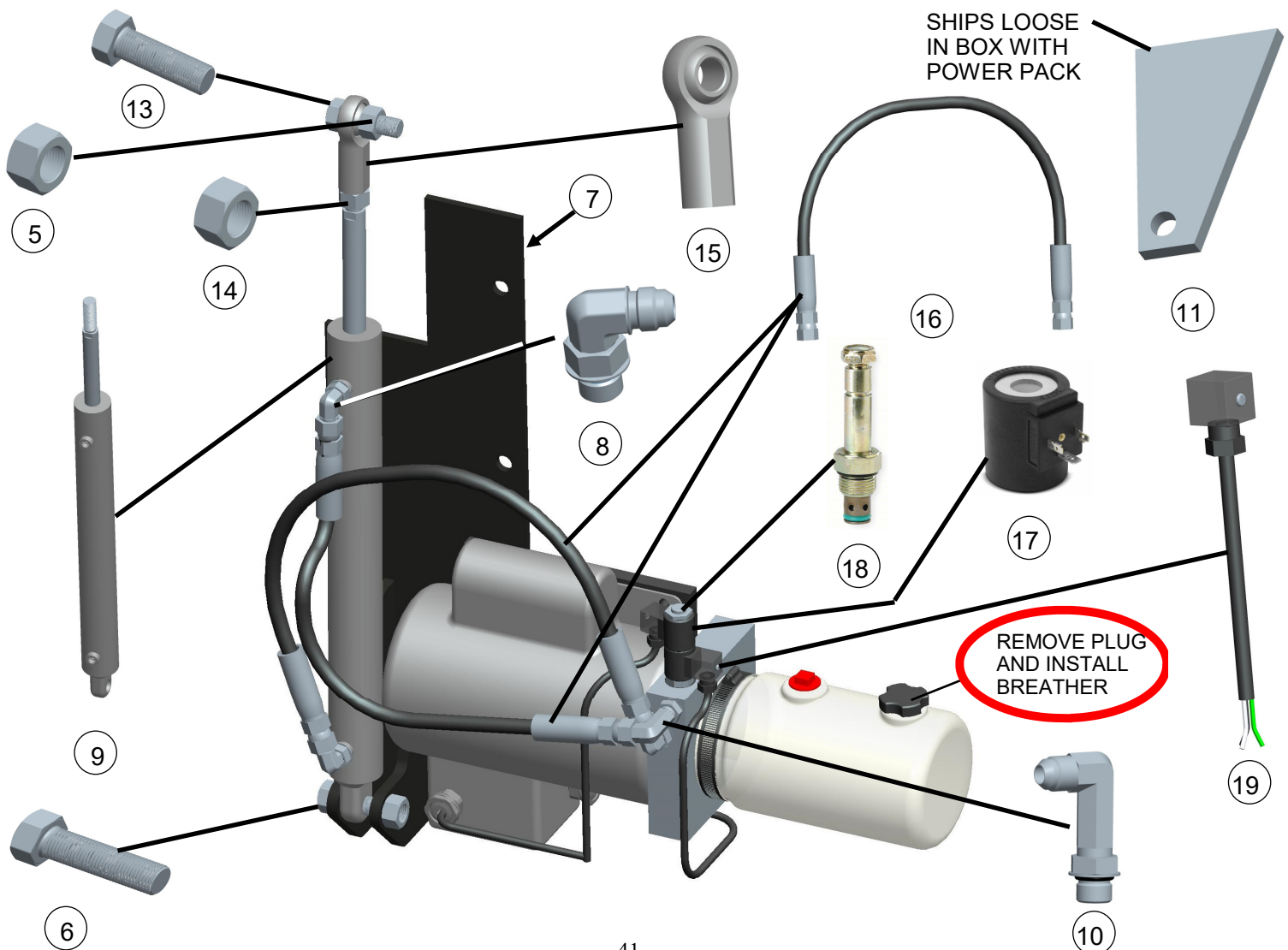



JH Industries, Inc.
1981 E. Aurora Road
Twinsburg, OH 44087

Phone: 1-330-963-4105

Fax: 1-330-963-4111

Toll Free: 1-800-321-4968

www.copperloy.com