

# DOCK TO GROUND RAMP

## Owner's Manual



*by*  
**JH INDUSTRIES, INC.**



Do not install, operate or service this product unless you have read and understand the Safety Practices, Warnings, and Installation and Operating Instructions contained in this manual. Failure to do so could result in serious injury or death.

---

# WARRANTY

SERIAL NUMBER \_\_\_\_\_

CUSTOMER \_\_\_\_\_

**ALL WARRANTY CLAIMS MUST HAVE PRE-APPROVED RATES, TIMES AND AUTHORIZATION NUMBERS PRIOR TO ANY FIELD WORK, IN ORDER TO BE ACCEPTED BY JH INDUSTRIES, INC.**

J H Industries, Inc. expressly warrants that any Dock to Ground Ramp sold by it will be free from defects in material and workmanship under normal use for a period of two (2) year on all structural parts from the earlier of, 1) sixty (60) days after the date of shipment, or 2) the date of installation of the Dock to Ground Ramp by the original purchaser, provided the purchaser maintains and utilizes the Dock to Ground Ramp in accordance with the Owners Manual.

In the event that the Dock to Ground Ramp proves to be defective in materials or manufacturing workmanship within the applicable period, J H Industries, Inc. will, at its option:

1. Replace the Dock to Ground Ramp or the defective portion thereof without charge to the purchaser, or
2. Alter or repair the Dock to Ground Ramp, on site or elsewhere, without charge to the purchaser.

This warranty IS EXCLUSIVE AND IS IN LIEU OF ALL GUARANTEES AND WARRANTIES, EXPRESSED OR IMPLIED BY ANYONE OTHER THAN J H Industries, Inc. sole warranty obligation shall be as set forth above.

The warranty does not cover any failure caused by improper installation, abuse, misapplication, overloading, or negligence. Parts requiring replacement due to damage resulting from vehicle impact, abuse, improper operation or lack of proper protection are not covered by this warranty. Seller assumes no responsibility or liability for (1) consequential damages of any kind which result from the use or misuse of the Dock to Ground Ramp; (2) damage or failure resulting from the use of unauthorized replacement parts or modification to the Dock to Ground Ramp; (3) damage resulting from the misuse of the Dock to Ground Ramp. THERE ARE NO WARRANTIES, EXPRESSED OR IMPLIED, WHICH EXTEND BEYOND THE DESCRIPTION ABOVE. THERE IS NO WARRANTY OF MERCHANTABILITY OR OF FITNESS FOR A PARTICULAR PURPOSE.

---

**J H Industries, Inc. warranties extend only to the product itself.**

**J H Industries, Inc. DISCLAIMS all liability arising out of the workmanship, methods and materials used by the installer.**

**J H Industries, Inc. DISCLAIMS all liability for premature wear, product failure, property damage or bodily injury arising from improper installation or maintenance.**

**WARRANTIES, whether expressed or implied, relating to workmanship and materials used in connection with the installation of J H Industries, Inc. products are specifically DISCLAIMED.**

---

# TABLE OF CONTENTS

WARRANTY ..... i

CONTENTS ..... ii

SAFETY PRACTICES ..... iii

INSTALLATION ..... 1

OPERATION ..... 2

MAINTENANCE ..... 2

PARTS LIST ..... 3



Do not install, operate or service this product unless you have read and understand the Safety Practices, Warnings, and Installation and Operating Instructions contained in this manual. Failure to do so could result in serious injury or death.

# SAFETY PRACTICES

## SAFETY PRACTICES

### **WARNING**

*Read these safety practices before installing, operating or servicing Dock to Ground Ramp. Failure to follow these safety practices could result in property damage, serious injury or death.*

READ AND FOLLOW THE OPERATING INSTRUCTIONS CONTAINED IN THIS MANUAL BEFORE OPERATING THE DOCK TO GROUND RAMP. If you do not understand the instructions, ask your supervisor to teach you how to use the Dock to Ground Ramp.

### **FOR ALL MODELS**

Never exceed 5 mph when driving on ramp.

Never exceed the rated capacity of ramp.

Never travel on ramp unless lip is securely on dock floor and attached safety chains are securely in place.

Do not use the ramp with equipment, material, or people on or in front of the ramp or lip.

Do not use the ramp if it looks damaged. Tell your supervisor it needs repair right away.

Do not use this unit to dock heights outside its intended working range.

If you have any problems or questions using the ramp, contact your supervisor for assistance.

Do not stop truck or attempt to change gears while ascending or descending ramp.

Always traverse the ramp with the forks toward the dock or elevated end..

# INSTALLATION

## INSTALLATION

### ⚠️ WARNING

Before installing the dock to ground ramp, read and follow Safety Practices on page iii.

Failure to read and follow installation procedures could result in serious injury or death.

1. If required, pour a concrete footer or apron per local codes and conditions. Allow to fully cure before installation of ramp. See Figure 1.
2. Attach safety chain brackets to dock face using the holes provided with 5/8" dia. anchors bolts to suit. See Figure 2 & 3

### NOTICE

All anchor bolt lengths must suit local codes and conditions. Type and depth of concrete will determine type and length of anchor bolts required.

3. Square up and locate ramp in position on the dock surface, keeping the bumper plates as close to the dock face as possible, to prevent ramp movement. See Figure 2.
4. Attach both safety chains to safety chain brackets on dock face. Allow as little amount of slack in chains as possible to prevent ramp from moving away from dock face. See Figure 2.

### ⚠️ WARNING

Not attaching or allowing to much slack in safety chains may cause the ramp to move and fall free from the dock surface, resulting in equipment damage, serious injury or death.

| SAFETY CHAIN BRACKET LOCATION CHART |     |     |     |
|-------------------------------------|-----|-----|-----|
| RAMP WIDTH                          | 70" | 84" | 96" |
| "L"                                 | 30" | 37" | 43" |

FIGURE 1

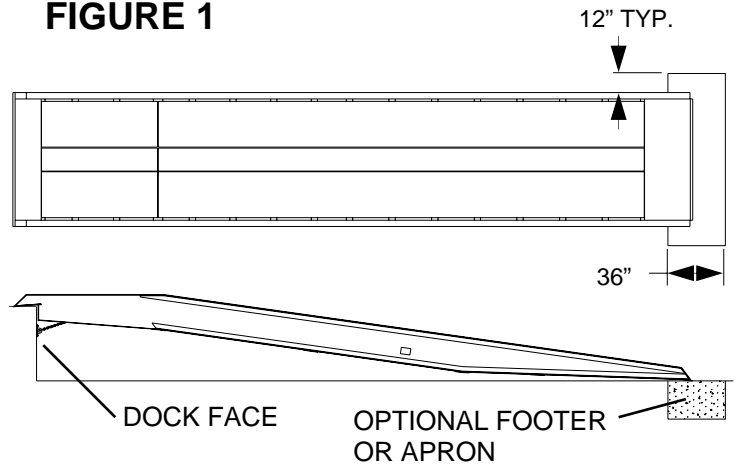

FIGURE 2

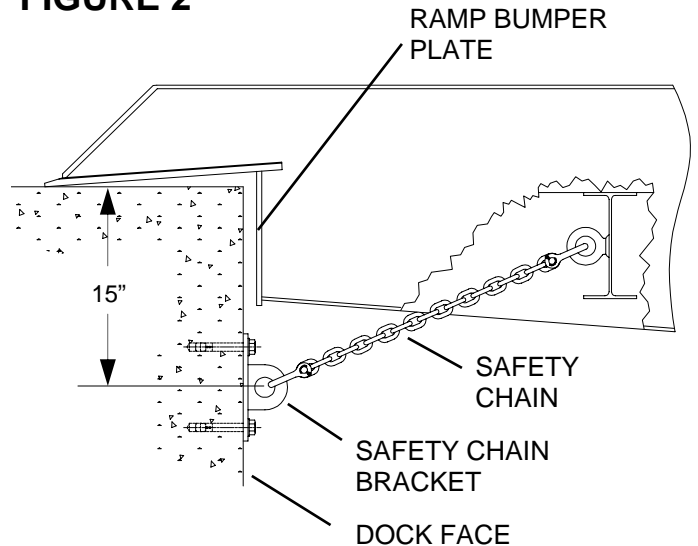
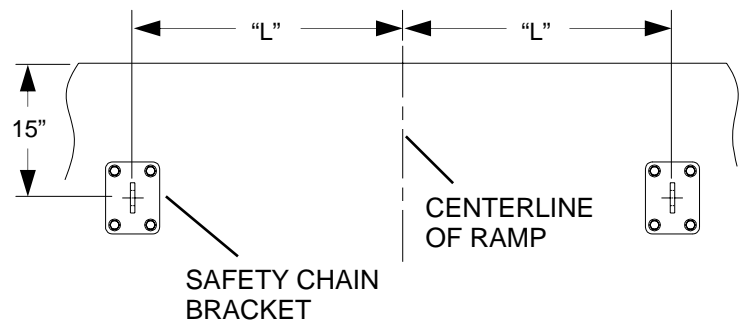

FIGURE 3



---

# OPERATION

## OPERATION

---

### **WARNING**

***Before using the Dock to Ground Ramp, read and follow Safety Practices on page iii.***

*Use by untrained people could result in serious injury or death. Read and follow complete Operation instructions. DO NOT USE THE RAMP IF IT LOOKS DAMAGED. Tell your supervisor it needs repair.*

*Always be certain that the attached safety chains are in place and secure, before ascending or descending the ramp. The use of the ramp without safety chains attached could cause the ramp to unexpectedly pull away from the dock, resulting in serious injury or death.*

---

## OPERATING

Approach the ramp with the fork truck or vehicle in low gear and maintain an even rate of ascending speed. DO NOT ATTEMPT TO ACCELERATE WHILE ASCENDING THE RAMP.

When traversing up the ramp toward the dock or elevated end be sure of door clearance with large loads. The loaded end of the lift truck should always be toward the raised end of the ramp with the forks and load above the grating.

Fork trucks should ascend and descend the ramp in the lowest gear. DO NOT STOP THE TRUCK ON THE RAMP TO CHANGE GEARS. This could cause lift truck tire spin and loss of control or undue wear and tear on the lifts tires.

---

# MAINTENANCE

## MAINTENANCE

---

### ANNUALLY

Inspect ramps enamel finish, touch up any areas indicating rust with a rust inhibitive coating.

Inspect grating for excessive wear and replace as required.

# PARTS LIST

## PARTS LIST: 36' Dock to Ground Ramp With 8' Level Off

| ITEM | QTY | DESCRIPTION  | P/N     |
|------|-----|--|---------|
| 1    | **  | Grating Panel, 2-1/4" Thick x 28-3/4" x 6'-3-3/4"  | 025-026 |
| 2    | **  | Grating Panel, 2-1/4" Thick x 14-1/2" x 6'-3-3/4"  | 025-028 |
| 3    | **  | Grating Panel, 2-1/4" Thick x 28-3/4" x 25'-4-3/4" | 025-025 |
| 4    | **  | Grating Panel, 2-1/4" Thick x 14-1/2" x 25'-4-3/4" | 025-027 |
| 5    | 2   | Pad, Eye, Safety Chain Bracket, Weldment           | 030-012 |
| 6    | 2   | Chain, Coil, Hi-Test, 5/16" x 21"                  | 009-051 |
| 7    | 4   | Shackle, Anchor, Round Pin, 7/16"                  | 030-011 |

\*\* Ramp width determines quantity

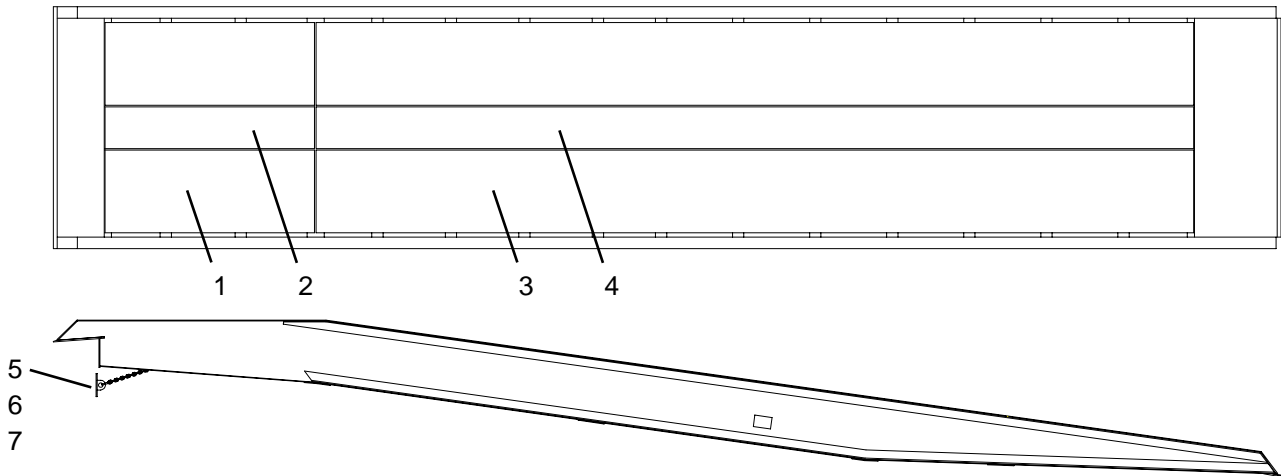

## PARTS LIST: 30' Straight Dock to Ground Ramp

| ITEM | QTY | DESCRIPTION  | P/N     |
|------|-----|--|---------|
| 1    | **  | Grating Panel, 2-1/4" Thick x 28-3/4" x 25'-4-3/4" | 025-025 |
| 2    | **  | Grating Panel, 2-1/4" Thick x 14-1/2" x 25'-4-3/4" | 025-027 |
| 3    | 2   | Pad, Eye, Safety Chain Bracket, Weldment           | 030-012 |
| 4    | 2   | Chain, Coil, Hi-Test, 5/16" x 21"                  | 009-051 |
| 5    | 4   | Shackle, Anchor, Round Pin, 7/16"                  | 030-011 |

\*\* Ramp width determines quantity

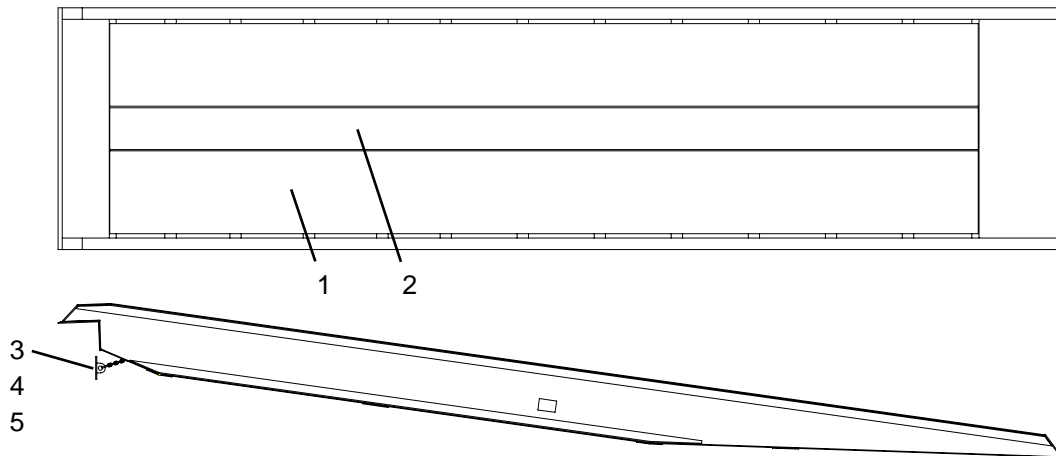

JH Industries, Inc.  
1981 E. Aurora Road  
Twinsburg, OH 44087

Phone: 1-330-963-4105

Fax: 1-330-963-4111

Toll Free: 1-800-321-4968

[www.copperloy.com](http://www.copperloy.com)